



UNIVERSITÀ DI PARMA

ARCHIVIO DELLA RICERCA

University of Parma Research Repository

Code of ethics and workers' communication policies: The role of corporate governance

This is the peer reviewed version of the following article:

Original

Code of ethics and workers' communication policies: The role of corporate governance / Furlotti, Katia; Mazza, Tatiana. - In: CORPORATE SOCIAL RESPONSIBILITY & ENVIRONMENTAL MANAGEMENT. - ISSN 1535-3958. - 27:6(2020), pp. 3060-3072. [10.1002/csr.2024]

Availability:

This version is available at: 11381/2883268 since: 2024-11-18T14:32:45Z

Publisher:

John Wiley and Sons Ltd

Published

DOI:10.1002/csr.2024

Terms of use:

Anyone can freely access the full text of works made available as "Open Access". Works made available

Publisher copyright

note finali coverpage

(Article begins on next page)

02 May 2026

Code of Ethic and workers' communication policies: the role of Corporate Governance

Abstract

A good monitoring that reduces agency conflicts can help in developing structured policies in code of ethics to help the social information processing for employees. The objective of this research is to investigate whether the corporate governance characteristics, such as duality, board of directors' size and independence as measures of monitor capacity are related to workers' communication policies disclosed in code of ethics. Based on a content analysis of code of ethics to defined the latter polices and on regression analyses on 808 firm-year observations, our results show that board of directors' independence is positively related to code of ethics policies related to communication with employees. Independence of the board is expression of supervising, supporting transparency and aiming to safeguard the best interests of all stakeholders, including employees.

Keywords: Ethics, Code of Ethic, Employees Policies, Corporate Governance

Introduction and motivation

Corporate social responsibility (CSR) emphasizes the relationship of the company beyond the only focus on shareholders, expanding the view to all stakeholders (Welford, 2007). One of the key internal company stakeholders that should be considered is the employee (Mazza & Furlotti, 2019; Pedersen, 2011; Young & Thyil, 2009), whose happiness allows to improve the relationship with the company with significant impacts such as reduced turnover, increased worker dedication and productivity or reduced labor disputes. A better working environment, moreover, can encourage the development of personal initiatives and the increase of performance, both at individual or company level. Workers are, in fact, an important part of community and, of society in general and their satisfaction can be an important vehicle for the legitimacy of the company (Balluchi & Furlotti, 2013). The potential benefits generated by the legitimacy of CSR increase when CSR is incorporated into human resource management (Diaz-Carrion, López-Fernández & Romero-Fernandez, 2020). Developing socially responsible management actions directed at employees, improves the company's image (Jamali, El Dirani & Harwood, 2015; Shen & Benson, 2016), reinforces the psychological contract between employees and company and enhances their commitment to the organization (Farrukh, Sajid, Lee & Shahzad, (2019), retains and motivates workers, positively influencing the firm's likelihood to survive in the long term (Barrena-Martinez, López-Fernández & Romero-Fernandez, 2019; Barrena-Martínez, López-Fernández, Márquez-Moreno & Romero-Fernández, 2015; Duarte, Gomes & das Neves, 2014; Kim, & Scullion, 2013). Recent labor rights abuses by corporations, increased due to the globalization, has requested the necessity to incorporate CSR and ethics criteria into human resource management and to include employees policies in code of ethics (CE) (Helfen, Schüßler & Sydow, 2018;

Martínez-García, Sorribes & Celma, 2018; Celma, Martínez-García & Coenders, 2014). Examples of these socially responsible management actions are policies and practices that contribute to employees' work-life quality (Aust, Muller-Camen & Poutsma, 2018).

Other socially responsible management actions are policies and practices that change the way employees can and are motivated to communicate their ideas and concerns within an organization. An important socially responsible management action can be the use of CE, which can be defined as a written document containing a set of rules developed by the company in order to guide current and future behavior. CE is a written document in which companies make clear their normative commitments (Painter & Morland, 2010) and the ethical values that move companies' strategies and workers' behaviors (Chun, 2019). The main interest of a company's CE is to share and communicate to workers the behaviors considered suitable to ensure the respect of the company's interests, that also respond to the expectations and pressures of the external context on how the company should behave (Adelstein & Clegg, 2016). The code outlines managers and employees' behavior toward each other, toward the company and stakeholders and society in general (Kaptein & Schwartz, 2008). Leaders and managers are responsible for empowering their workers to act in ethically and for guiding the firm's strategy toward the inclusion of ethic as central component (Garegnani, Merlotti & Russo, 2015). Consequently, the top management's participation to ethics programs and the commitment from the top are key elements for the effectiveness of CE.

Many researchers underline the importance of considering CSR and CE as separate elements and analyse the mutual impacts of the initiatives that are reported in CSR reports or sustainability reports and the most widely used tools for defining and communicating internally and externally the ethical approach to corporate action, as CE is. Harrison, Ferrell, Ferrell, and Hair (2019), for

instance, underline the confusion emerging because of dissimilar and overlapping definitions of CSR and CE, and because of the great number of studies that consider CSR and ethics exchangeable; they illustrate the recent studies that consider, instead, these concepts separate (e.g. Ferrell, Harrison, Ferrell, and Hair, 2019). Mason and Simmons (2013) suggest the importance of distinguishing CSR from business ethic; in particular, they consider business ethic a kind of internal response to company's opinion about CSR and, at the same time, a determinant of CSR performance.

Our research is focused, in particular, on CE and on its ability to be a worker communication tools and it aims to analyze the link between worker communication policies in CE and the companies' corporate governance (CG) characteristic. Several researches, have analyzed the link between company's corporate governance and company's CSR; Jizi (2017), suggests that despite the growing number of studies focused on corporate governance and on CSR, separately considered, studies about the link between CG and CSR can be improved, also because evidences remain mixed. Other researches have aimed to analyze the link between CG and business ethics (e.g. Şahin, 2018). In the path of these studies we want to develop the analysis of the relationship between CG characteristics and CE, with particular regard to CE ability to be a worker's voice tool. CE can include policies related to downward communication from managers to subordinates, but also bottom up communication called "worker voice" from employees to managers that has received less attention in literature (Ahmad et al., 2019). We answer at the call of empirical studies on the formation of factors that leads to employee's participation (Chaudhary, 2017; Rupp et al., 2018), considering the bottom up communication as employee's participation opportunity. We contribute to this literature analyzing specific CE contents of particular relevance as far as worker voice is concerned: "CE policies related to communication with employees". We

draw this CE content from the category “Effective communication” in the framework of Spiller, (2000). These policies show the ability of the code to clarify the communication tools toward employees.

In particular, our research aims to analyze the link between these aspects of the CE and corporate governance characteristics related to Board of Director (BoD) and Chief Executive Officer (CEO). We study BoD and CEO as monitoring instrument to reduce agency conflict based on agency theory (Jensen & Meckling, 1976). In response to shareholder activism with regard to issues such as labor rights, human rights and environmental protections, BoDs and CEOs in the corporate governance system have increasingly been charged with proposing and monitoring strategic decisions related to social responsibility and ethic policies (Cook & Glass, 2018). On the best of our knowledge, we are the first to consider corporate governance in the relationship between social responsible employees-supportive policies about communication tools disclosed in CE. We study these communication policies as instrument to give social information to employees to influence their behavior based on social information processing theory (Salancik & Pfeffer, 1978). We define three main hypotheses: Board of Director size is positively related with CE policies related to communication with employees; CEO duality is negatively related with Communication with employees; Board of Director independence is positively related with CE policies related to communication with employees.

Based on the methodology of prior literature (Campopiano & De Massis, 2015; Liao, Shih, Wu, Zhang & Wang, 2018; Preuss, Barkemeyer & Glavas, 2016) we use a content analysis on the documents of 202 (808) Italian firms (observations) for the period 2013-2016 and we run multivariate ordered probit regressions to test the relations with corporate governance.

The paper proceeds as follows. First, we discuss the main existing literature and the theories used as basis. Then, we discuss the hypotheses development. Next, we discuss the methodology and multivariate regression models, defining the sample selection, the data collection and content analysis and explaining the univariate and regression results. Finally, we argue some discussion and conclusion highlighting the research and managerial implications of the study findings.

Theoretical framework

Agency theory, corporate governance and code of ethics

Corporate governance studies are grounded in the agency theory (Jensen & Meckling, 1976). Agency theory aims to explain, control and solve the potential problems emerging in the relationship between a principals and their agents. The agents act for the principal in a transaction and they are expected to support the best interests of the principal. The thinkable different interests of principals and agents can create a conflict and some agents can act not in the principal's best interests. This leads to the principal-agent problem that can occurs when the interests of a principal and agent conflict. In a company, the relationship to manage is between shareholders (principals) and company mangers (agents) and it is possible to assumes that there is an intrinsic conflict between the owners of a firm and its managers who can manage the company to pursue more their personal interest respect to the owners' ones (Jiraporn, Potosky & Lee, 2019).

In this respect, corporate governance system aims to manage the rules under which the agent operates maintaining the principal's interests; the BoD must monitor the managers' actions and behaviors to safeguard the interests of shareholders and other stakeholders (Jensen & Meckling, 1976). Thus, many instruments, such as corporate governance code or CE, can be useful in order to ensure the alignment between the principals' interests and the management's behavior. Many

researches underline the importance of the directors' involvement in CE plan (Heidrick & Struggles, 2004) and CE fulfillment supervision (Berenbeim & Kaplan, 2004; Jones & Pollitt, 1999).

Moreover, it is fundamental the ability of the management to involve all the various company stakeholders in the preparation as well as in the dissemination and implementation of the CE. Among stakeholders involved, employees are fundamental ones (Helfen et al., 2018). An essential characteristic that qualifies CE, in fact, is its ability to represent the whole company, requiring sharing and acceptance by the entire organization. In this sense, every aspect in the CE must be understood and approved by all members of the organisation. Several studies have been carried out in this regard, especially with a view to analysing the effectiveness of the CE (Kaptein & Schwartz, 2008, Schwartz, 2002). To make the CE effective, management should present the initiative of the generation of CE, sharing its interest in developing it with different areas or interested parties. The collaboration and the involvement of different areas should be stimulated by BoD and CEO. As governance plays a key role in the CE drafting process, in the effectiveness of the engagement of all strategic areas, many studies have focused on the relationship between the presence of a CE and several characteristics of companies' corporate governance. Prior literature has analyzed, for example, BoD specific characteristics such as the percentage of outside directors, the ownership by its members, its size and diversity (Baselga-Pascual, Trujillo-Ponce, Vähämaa & Vähämaa, 2018; Rodriguez-Dominguez, Gallego-Alvarez & Garcia-Sanchez, 2009). Prior literature analyzed the relationship between corporate governance and CE in general. Schwartz (2002) underlines the importance of the role of the board of directors (BoD) and of all senior managers in supporting the CE, also because of the signal by different institutional guidelines, such as the guideline by Organisation for Economic Cooperation and Development, by

New York or Australian Stock Exchange, or the Higgs report in the United Kingdom (Bonn & Fisher, 2005).

We contribute to this literature investigating the existence of a relationship between these characteristics of companies' corporate governance and the content of CE with reference to a specific and under investigated stakeholder: the employees. Different stakeholders have different information needs, thus the analysis of a specific stakeholder instead of a general analysis of CE could give useful insights. In addition to ensure the shareholders-managers alignment, the same instruments can be useful to ensure the alignment between the other stakeholders' interests and the management's behavior. For example, a high quality corporate governance can help in developing policies to reduce the only self-driven actions and in promoting actions in favor of other stakeholders, such as employees. A good monitoring can help in developing structured policies in CE formal documents to help the communication from and towards employees, as a new modes of worker voice practice.

Social information processing theory and code of ethics

Social information processing theory (Salancik & Pfeffer, 1978) explains job attitudes starting from the analyses about how mental operations affect behavior replying to specific social situations. The theory highlights the effects of context and the consequences of past choices, rather than individual predispositions and rational decision-making processes (Dodge & Rabiner, 2004). According to this theory, workers try to understand their work situations by exchanging information. Specifically, when the situation is complex or unknown, social information are essential for employees, even more than the leadership behavior (Yang, Huang & Wu, 2019).

Thus, social responsible CE policies related to communication with employees (Effective communication in Spiller, 2000) can promote a correct understanding of the ethical and social aspects related to the work. They may clarify the role that employees can have in and for the company, not only in terms of production but also with regard to the social effects related to it.

Prior literature mainly focus on social responsible employees' policies in sustainability reports, studying policies applied by firms year-by-year, mainly using content analysis for professional standards from Global Reporting Initiative (e.g. Barrena-Martinez et al., 2019). Instead, we focus on policies that should be followed every year. They should form the values of the company and they are formally written in a public disclosed firm's document, i.e. the CE. CE policies are considered absent when there is no information on communication in the whole document of code of ethic; are considered as a minimum level when there is information only on general communication with and without specific communication tools developed inside the firm. On the other hand, CE policies are considered good level of communication toward employees when there is specific information on communication for employees with and without specific communication tools developed inside the firm.

Prior evidences show that social information processing theory is confirmed for the impact that social information on work social situation in CE has on job attitudes. The definition of ethical choices and rule of behavior on CE can have deep effects on the individual and, afterward, on the organization. Some studies show the impact of a CE in improving the employees' work climate (Manley, 1991) and in promoting a humane way of living and working for employees (Williams & Murphy, 1990). Others show its impact in the guarantee of workplace health and safety (O'Dwyer & Madden, 2006) and in the definition and disclosing of the values to which everyone, including employees, in the organization should follow (Weaver, 1993). Other studies investigate

companies' codes of ethics in order to understand how CE relates to the ethical values of individual workers and how the code's rules can be accepted and become workers' own rules of conduct (Arifeen & Gatrell, 2020). Sobczak (2006) analyses the legal nature of CE and its impact on labor and employment law. He analyzes the employee's perspective from the legal point of view. Adopting a CE can be considered a system to formalize, support and manage responsible behavior among employees and organizations (Bondy, Matten & Moon, 2004).

We study if corporate governance characteristics have a relationship on the social information on work social situation written in CE, given that this information drives job attitudes and satisfaction can be an important vehicle for the legitimacy of the company (Balluchi & Furlotti, 2013).

Framework

Figure 1 shows the conceptual framework that we adopt. We develop 3 hypothesis based on 3 main characteristics of corporate governance that analyze the reduction in agency conflicts based on the monitoring role of BoD and chief executive officer (CEO). These three characteristics are respectively BoD size for H1, CEO duality for H2, BoD independence for H3. They are observable variables from corporate governance report and so they are represented in a square in the Figure. The relation (positive for size and independence and negative for duality) with the unobservable concept of agency theory (showed in a circle in the Figure) is explained in detail in the following section related to hypothesis. In summary, BoD and CEO must monitor the managers' actions and behaviors to safeguard the interests of shareholders and other stakeholders and reduce agency conflict (Jensen & Meckling, 1976). Specific characteristics of BoD and CEO (size, independence and duality) can increase or decrease this monitor capacity.

Framework in Figure 1 shows that we develop the link toward policies disclosed on CE on communication toward employees. They are observable variables from CE documents and so they are represented in a square in the Figure. CE policies related to communication are a direct (+) expression of the unobservable concept (in circle in the Figure) of social information processing theory. Based on social information processing theory, a specific social situation influences mental and behavior in job attitudes at the expense of rational decision-making processes (Dodge & Rabiner, 2004; Salancik & Pfeffer, 1978). The stakeholder employee tries to understand its work social situations to adapt its behavior (Yang et al., 2019) and CE, including employees' policies, is an instrument to get access to this information.

(INSERT FIGURE 1 HERE)

Hypothesis development

A firm's CEO and top managers in the BoD have operational discretion and monitoring power on enacting policies that will address the firm's human resource management needs and goals (Jiraporn et al., 2019). Good BoD mechanisms enhance the fairness among the different stakeholders in the business (Matten & Crane, 2005; Jensen, 2001). Based on this argument, we expect that corporate governance plays a role in enhancing the social responsible policies related to employees in CE to reduce information asymmetry between managers and stakeholders. The main corporate governance characteristics that can influence worker voice policies in CE are BoD size, CEO duality and BoD independence because they act on the monitoring of the management decision.

We expect that higher BoD size is positive associated with social responsible policies about worker voice in CE. We expect this relation because BoD size increases monitoring. A large

BoD carries out better supervision of the management team and makes corporate decisions of higher quality (Pearce & Zahra, 1992). The individual workload of directors tends to be high in small BoD, limiting its monitoring ability (John & Senbet 1998).

Furthermore, greater monitor promotes a more careful and widespread communication to everybody, as well as attention to the correct understanding and knowledge of tools, improving the possibilities for employees to understand their work situations, as social information processing theory predicts to be a purpose of employees. Thus, we expect that BoD size ensures transparency also in CE about CE social responsible policies related to communication with employees:

Hp1: Board of Director size is positively related with CE policies related to communication with employees

We expect that higher CEO Duality is negative associated with “CE policies related to communication with employees” because it decreases monitoring. When the chairman also serves as CEO, the monitoring function is weakened because decision-making power is not separated from the controlling power (Tuggle, Sirmon, Reutzel & Bierman, 2010).

Empirical research suggests that the level of social accountability is negatively affected by CEO duality (Chau & Gray 2010; Donnelly & Mulcahy 2008). The CE as social disclosure instrument can be used by the CEO for his own interests and moral convictions. In this respect, in fact, CEO is disinclined to implement policies for developing comprehensive and high quality communication to exchange social information in the interests of stakeholders toward employees.

Hp2: CEO duality is negatively related with Communication with employees

Regulations has strengthen the role of independent non-executives directors as a solution to corporate governance failures (Ng & Roberts, 2007). We expect that higher BoD independence is positive associated with “CE policies related to communication with employees” because it increases monitoring. Independent directors are governed by the same legal responsibilities of other directors, but the role of independent make them to have a more critical opinion on the firm’s activities and to be freer to support unpopular and costly decisions (Arora & Dharwadkar 2011). Independent directors are considered in the literature as proxy for higher monitoring (Baysinger & Butler, 1985; Beasley, 1996; Klein 2002). Independent directors enhance the control role of boards, particularly in areas such as board appointments, audit and remuneration where there is the strongest potential for conflicts of interest between executives and shareholders (Ng & Roberts, 2007). Growing evidence suggests that independent directors who serve on multiple corporate boards exercise greater influence over firm outcomes, they are viewed as trustworthy and are granted greater and they are associated with innovative policy adoption (Cook & Glass, 2016), and more company’s ethical behavior (Fombrum & Shanley 1990; Johnson & Greening 1999). Independent directors are generally interested in showing compliance with regulation and the ethical behavior (Ibrahim & Angelidis 1995; Prado-Lorenzo & Garcia-Sanchez 2010; Garcia-Sanchez, Rodriguez-Dominguez & Gallego-Alvarez, 2011). They also consider the impact of compliance and control on their own reputation (Frias-Aceituno, Rodriguez-Ariza & Garcia-Sanchez, 2013; Garcia-Sanchez, Cuadrado-Ballesteros & Sepulveda, 2014). In fact, there are empirically evidences that independents directors better control possible unethical conduct and fraud (Beasley 1996; Garcia-Sanchez, Rodríguez-Domínguez & Frías-Aceituno, 2015).

H_{p3}: Board of Director independence is positively related with CE policies related to communication with employees

Methodology and multivariate regression models

To test our hypotheses, we estimate equations (1):

“*CE policies related to communication with employees*”=

$$\beta_0 + \beta_1 \text{Corporate governance} + \beta_1 \text{Size} + \beta_2 \text{Loss} + \beta_3 \text{CFO} + \beta_4 \text{CATA} + \beta_5 \text{Leverage} + \beta_6 \text{Sales growth} + \text{industry fixed effects} + e \quad (1)$$

Table 1 includes variables definition.

(INSERT TABLE 1 HERE)

We use multivariate ordered probit regression models with robust standard errors. Equations are estimated with industry fixed-effects in order to control for systematic differences across industries. “*CE policies related to communication with employees*” is an ordinal variable resulting from the content analysis explained in the next section.

We use the following *Corporate Governance* variables: (1) BoD Size, (2) CEO Duality, (3) BoD Independence. We include BoD size as number of directors (Baselga-Pascual et al., 2018). We include CEO Duality as an indicator variable equal to 1 if the CEO is also the Chairman of the BoD, and equal to 0 otherwise (Liu & Lu, 2007). We include BoD independence as the percentage of BoD members that are independent (Liu, & Lu 2007; Yeh, Shu & Su, 2012). The coefficient sign expectations are based on the three hypotheses: (+) BoD Size, (-) CEO Duality, (+) BoD Independence.

We include control variables to run a multivariate analysis that takes in consideration incentives and firms’ characteristics that can influence CE policies. These variables are drawn from

the literature. We use *Size* as proxy of capital market pressure (Dechow, Ge & Schrand, 2010) because this external pressure can create incentives to set CE policies. We include *Loss* as proxy for incentives for lower quality disclosure (e.g., Dechow et al., 2010), including CE as type of disclosure. We add cash flow from operations (*CFO*) and current assets over total assets (*CATA*) as proxy for client-risk (Dechow et al., 1995) in addition to *Leverage* as proxy for likelihood of debt covenant violation (e.g., Dechow et al., 2010; DeFond & Jiambalvo 1994) because risks and possibility of debt covenant violations are indicators of firms' characteristics that can also influence CE policies. Finally, we use *Sales growth* as proxy for the economic life cycle, because in different phases of the life cycle companies can set different CE policies.

Sample selection, data collection and content analysis

We select Italian firms listed on the Milan Stock Exchange that are available on Bureau Van Dyck database. We exclude the financial sector from our analysis because of its dissimilar nature and settlement. We delete 37 firm observations without financial statement data. We hand-collect the CE from the companies' websites and we exclude 52 companies without a CE. Finally, we hand-collect Corporate Governance Reports from the companies' websites and we exclude 16 companies without this report. We have a final sample of 202 firms for 4 years (2013-2016) resulting in 808 observations (Table 2, Panel A). We have selected this period based on the available Corporate Governance Reports in the archive online of the website of the listed firms analyzed.

The industry coverage of these non-financial listed firms with voluntary disclosure of CE and with transparency data for Corporate Governance report is shown in Table 2, Panel B. The highest industry covered is Manufacturing (plastic, leather, glass, metal, machinery, equipment), followed by Transportation, Communications, Electric, Gas and Sanitary service.

(INSERT TABLE 2 HERE)

We use the manual content analysis often used within voluntary disclosure research since years (Abbott & Monsen, 1979). We applied the so-called ‘third party approach’ where the analysis is carried out by someone who is neither the provider nor the receiver of the report (Gamerschlag, Möller & Verbeeten, 2011). Content analysis can have advantages related to the reduction of interviews’ biases (Barr, Stimpert & Huff, 1992) and to greater reliability and replicability (Potter & Levine-Donnerstein, 1999). We use the methodology based on the development of keywords (Campopiano & De Massis, 2015; Liao et al., 2018). Reading the CE, we search information about “CE policies related to communication with employees”. If we find a category, we underline a keyword that the company has used, and we report this keyword in Table 1. The list of keywords can be useful in future research or to replicate the study. We develop a list of keywords for each item. In sum, the content-analytic procedure was performed by adapting the seminal content analysis methodology of Neuendorf (2002) following stages: (i) we inductively generated first-order keywords from reading the CE, integrating them with insights from existing literature, adding keywords when new facts or factors emerged in the reports (Tsui-Auch, 2004); (ii) when keywords were named, we reviewed the data for the other companies in the sample. At times, the data did not fit well into a category, which led to either abandoning or revising (Pratt, Rockmann & Kaufmann, 2006). The identified keywords finally help us to develop the category with 4 levels: 0) no information on communication, 1) information only on general communication; 2) information only on general communication but with specific communication tools developed inside the firm; 3) specific information on communication for employees; and 4) specific information on communication for employees with specific communication tools developed inside the firm.

In the downloaded corporate governance reports, we hand collect data about information for individual board members, including name and independence classification. Following Jiraporn et al. (2019), given that firms track individual BoD members over years, we collapsed the characteristics of each BoD member data into firm-years for the period 2013-2016. Firms' characteristics are from Bureau Van Dyck database. Given the use of corporate governance reports to measure the independent variables of interest, we use panel data using the yearly variation of information about corporate governance to have a larger sample of analysis more independent from the macroeconomic situation of a single specific year.

Univariate results

Descriptive statistics of mean, standard deviation, 25th quartile, median, 75th quartile, minimum and maximum are showed in Table 3.

BoD Size shows an average of 9 members in a context where BoD goes from 2 to 24 members. Italian regulation for listed firms says that BoD can be a BoD of 2 or more members (no single director in listed companies). There is no guideline on the best number of members or on the maximum number. The Italian regulation says that company Statute declares the number of Directors that composed the BoD, or the minimum and maximum number of directors. In this case will be the Assembly of the owners that will decide the number of directors in order to ensure a competent management of the companies. The BoD shall be made up of executive and non-executive directors. The number, competence, and time availability of non-executive directors shall be such as to ensure that their judgement may have a significant impact on the taking of BoD decisions.

CEO Duality shows that 41.6 percent of the sample has a CEO that is also a BoD chairman. The average number of independent directors is 4 and goes from 0 to 15. The average of percentage of directors over the total is 41.9 percent, from BoD with 0 percent of independent directors to 90 percent of independent directors. It is not possible to have 100 percent of independent directors because at least the CEO is not independent. The Italian regulation says that an adequate number of non-executive directors shall be independent that means that they do not maintain any business relationships with the company, able to influence their autonomous judgement. The directors' independence shall be assessed by the BoD after the appointment and then on a yearly basis. The self-regulatory Corporate Governance Code by the Italian Stock Exchange asks to listed companies to have at least two independent directors in the BoD. When a company choose not to be comply with the Code, it is also possible to have BoD without independent directors. In fact, it is possible to follow the self-regulatory code according to the comply or explain principle, which allows not to adhere to certain specific requirements, if the requests of the code are not applicable or are applicable with a worsening rather than improvement of government conditions. In this case, it is necessary to adequately justify the reasons for the defection. Firms' characteristics are consistent with the literature. Average of 6 of logarithm of total assets, 27 percent of the sample of firms with a loss, average of cash flow form operation of 8.5 percent of total assets, average of current assets of 47 percent of total assets, average of long-term debts of 17 percent of total assets, and an average growth rate of 3.9 percent of sales.

Table 3 in Panel B shows the distribution of the five codes of the ordered variable CE policies related to communication with employees from level 0 to level 4. Considering the CE is a voluntary document with no guideline of preparation, it is not surprising that a lot of the firms

(300 observations) have no information on CE about general communication within the firms (Level 0). Many firms do not have a session in CE dedicated to communication or transparency.

The largest part of our sample (412 observations) have included in CE information about communication with stakeholders, but without specifying the communication with employees (Level 1). Other 48 observations have information about communication with stakeholders, without specific communication policies for employees, but have specific communication tools developed within the organization (Level 2). Most of this information is provided in a specific section of CE called “Communication” or “Transparency”.

The Level 3 is the level that we consider the starting point of a good policies definition about communication with employees. We can see from this distribution, that in the Italian sample analyzed, it is not very frequent (40 observations); however, there is a begin of its consideration in CEs. Most of this information is provided in a specific section of CE called “Relationships/Involvement with employees and collaborators” where there is a part dedicated to Communication. Level 4 (8 observations) is the top of the category with detailed policies about communications for employees. Only two firms for their four-year period have this detail in CE. In these last levels, we are able also to follow Marchington and Dundon (2017) in addressing the emerging interplay of multi-level actors, including employees associations and employees representative to understand how they sustain worker voice. Some of the firms in fact have as CE policies the presence of an employer representative or of a developed relation with employees associations, which promotes also employees communication.

Correlation matrix in Table 4 shows that the correlation with “CE policies related to communication with employees” is significant only for BoD size and BoD independence. Moreover, the correlations among corporate governance variables (BoD size, CEO duality, BoD independence)

is 20/30 percent. Thus, to avoid multicollinearity we use the single variables in three different models in the multivariate analysis. Beyond size, other control variables are not highly correlated. Size has a low variance inflation factor, thus, given the importance to control for firm size in explaining CE disclosure, we keep size in the multivariate analysis.

(INSERT TABLE 3 AND 4 HERE)

Regression results

Table 5 shows the multivariate regression results for three models to test the three hypotheses in relation with “CE policies related to communication with employees”. Model 1 tests the relation with BoD Size, Model 2 tests CEO Duality and Model 3 tests BoD Independence. Based on the analysis of control variables, larger firms or flexible firms with high current assets are associated with more reporting in CE about policies related to communication with employees. On the other hand, firms with high value of cash flow from operation or low level of leverage or growing firms have a negative association with “CE policies related to communication with employees”. All the models are tested on 808 observations for the period 2013-2016 and include industry fixed effect and robust standard errors.

For the variable of interest, we can see that only hypothesis 3 is confirmed: BoD Independence is positively and significant associated with “CE policies related to communication with employees”. The magnitude of the relation in the ordered probit regression is 0.977. This correspond to an Estimate of 0.739 with an ordinary least square regression. This means that increasing one unite of independent variable, i.e. 1 percent of BoD Independence, the dependent variable CE policies increase in average of 0.739 unites. Given the ordered variable of CE policies, an increase of 1 point from one category to another in a range of only five possible categories is an

economic relevant increase. In other words, to pass from an absent disclosure on CE to a disclosure of communication policies, a firm should increase the independence of BoD of only a little more of 1 percent in average situations (increase of 1.35%). The same is true for communication related to employees. Respectively from zero disclosure to generic communication tools, there is a need of an increase in BoD independence of 2.71%. To pass from an absent disclosure to a CE that includes polices that address worker voice a firm should appoint more independent directors to increase the percentage of a bit more of 4 percent in average (4.06%). Respectively from zero disclosure to communication tools for employees, there is a need of an increase in BoD independence of 5.41%.

Untabulated robustness results of regressions excluding firm *Size* give unchanged results on the significant relationship of BoD independence. Even if the Variance Inflation Factor of Size is low, the correlation between Size and BoD independence (Pearson correlation coefficient of 44.1%) could be a signal of multicollinearity, but excluding this variable does not change the results, showing robust results.

Looking at specific examples, the presence of many independent directors aims to guarantee a definition of a CE suitable for employee, with the inclusion in the code of policies about communication of principles, objectives, norms of behavior and values toward all stakeholders (see CE of Infrastrutture Wireless, 2017 in Appendix) and/or with specific communication tools (see CE of Best Union SPA, 2015 in Appendix). Thus, the presence of independent directors can help the clear comprehension of the CE by the employees, and can also increase an engagement of employee in the companies.

(INSERT TABLE 5 HERE)

Discussion and conclusion

In the path of the implementation of CE in organization to limit corporate scandals and unethical behavior, our study examines CE social responsible policies related to communication with the stakeholder employees. We study the aptitude of the code to profile employee behavior by establishing communication tools for them as a new mode to promote worker voice practices with not only a downward but also a bottom up approach to give voice to employees.

Our approach to investigate communication shows that in Italy the worker voice systems and voice opportunities in organisations in the form of formal polices in CE are still quite underdeveloped. Few firms have worker voice policies about specific information on communication for employees with or without specific communication tools developed inside the firm. Most of this information is provided in a specific section of CE called “Relationships/Involvement with employees and collaborators” where there is a part dedicated to Communication. However, this situation is not completely negative. This is a first indication that some firms have started to give importance to this issue, also with formal policies, including bottom up policies, in a written document as a mode to promote worker voice practices.

As an answer to the question of what is the link between workers’ voice policies in the CE and corporate governance, our research confirms the key role of the BoD in proposing and monitoring strategic decisions related to social responsibility (Cook & Glass, 2018) also with regard to decisions related to promoting the worker voice in firm-driven CE.

This research shows that BoD Size and CEO Duality are not related to “CE policies related to communication with employees” while BoD Independence it is. The positive effect related the good supervision of large BoD and the supervision when the chairman does not serve as CEO

and the decision-making power and controlling power are not in the same subject are not enough to promote “CE policies related to communication with employees” in the sample under analysis.

We support the importance of the role of BoD in supporting the CE (Baselga-Pascual, et al., 2018; Rodriguez-Dominguez et al., 2009; Schwartz 2002), adding empirical results on CE policies specifically related to employees. In particular, our results confirm seminal literature on the independence of the BoD. We settle that the latter is expression of supervision and it is aimed to safeguard the best interests of all stakeholders reducing agency problems (Baysinger & Butler, 1985; Beasley, 1996; Klein 2002) providing evidences related to CE and worker voice.

We confirm seminal literature on the view of independent directors as trustworthy associated with higher company’s ethical behavior (Fombrum & Shanley 1990; Ibrahim & Angelidis 1995; Johnson & Greening 1999). This result can be explained with the importance given to their personal reputation (Frias-Aceituno, et al., 2013; Garcia-Sanchez, et al., 2014) that promotes the firm’s compliance with ethical behavior. We provide further empirical evidences on the higher ethical behavior of companies having a large component of independent directors in their boards throughout the use of policies in favor of employees disclosed in CE.

We indorse that independent directors support unpopular and costly decisions (Arora & Dharwadkar 2011), adding evidences that these directors support the costly decisions to implement and make a detailed disclosure of policies related to specific communication with employees. The implementation of these policies is costly in the terms to create it involving the related stakeholders and in the terms to maintain it in the communication year-by-year to employees. We show empirical evidences also on the support of innovative policy adoption (Cook & Glass, 2016), such as the policies to set up specific communication tools.

The presence of many independent directors aims to guarantee a definition of a CE suitable for employee because principles and rules can represent employees' interest and needs, like the need of communication. Thus, the independence of the BoD is enough to promote "CE policies related to communication with employees". We contribute to social information processing theory for employees (Yang, Huang & Wu, 2019) empirically showing a determinant of the possibility to process work and social information, i.e. the development of the possibilities for employees to understand their work situations and process social information is promoted by a high independent BoD. Given that, CE has an impact on work climate and workplace health and safety (Manley, 1991; Williams & Murphy, 1990; O'Dwyer & Madden, 2006), a large component of independent directors, indirectly promoting policies in CE, can improve the work environment in these terms.

This research is not without limitations. The study is focused on specific variables of CE. Prior literature (Spiller, 2000) has proposed other issues related to CE characteristic and variables that can be investigated. This calls for further investigation of the other characteristics. Secondly, the content analysis is a discretionary tool that can give different results based on the people involved in the analysis of the documents. We followed prior practice to use the tool of content analysis but we underline it also as a possible limitation. Thirdly, we use proxy related to high quality governance based on literature, however for lack of available data we do not analyze other proxies (i.e. board diversity) and we are aware that they are proxies and that they do not capture in full the concept of corporate governance quality. We are also aware that we do not study the real employees' ethical practices but that we are studying the content of the CE, thus we do not claim to assess the "effectiveness" of CE. However, we think that the content of CE is

an interesting analysis and give information on which policies firms define and voluntarily disclose for their employees.

Our results have interesting implications for companies. We show the challenges to the organization in the corporate governance structure. BoD should be organized to include independent directors to have a well-designed CE in term of information on principles of communications for employees. This organization can bring indirectly also to improved work environment and climate. Companies should invest in having a high number of independent directors over the total number of BoD members. Future research could analyze other samples with other settings' characteristics, for example from other countries, to extract implications from BoD size or CEO duality that could be generalized in other contexts.

References

- Abbott, W. F., & Monsen, R. J. (1979). On the Measurement of Corporate Social Responsibility: Self-Reported Disclosures as a Method of Measuring Corporate Social Involvement, *Academy of Management Journal*, 22(3), 501–515.
- ~~Adam, M. A. & D. Rachman Moore (2004), 'The Methods Used to Implement and Ethical Code of Conduct and Employee Attitudes, *Journal of Business Ethics* 54, 225–244.~~
- Adelstein, J., & Clegg, S. (2016). Code of ethics: A stratified vehicle for compliance, *Journal of Business Ethics*, 138(1), 53-66.
- Aguinis, H., & Glavas, A. (2012). What We Know and Don't Know About Corporate Social Responsibility: A Review and Research Agenda, *Journal of Management*, 38(4), 932–968.
- Ahmad, Z., Ali, G., Mirza, H. H., Yousaf, U., Ahmer, Z., & Usman, B. (2019). Employees' response to code of ethics and corporate philanthropic social responsibility: Evidence from Pakistan. *Journal of the Research Society of Pakistan–Vol*, 56(2).

- Arifeen, S. R., & Gattrell, C. (2020). Those Glass Chains that Bind You: How British Muslim Women Professionals Experience Career, Faith and Family, *British Journal of Management*, 31(1), 221-236.
- Arora, P., & Dharwadkar, R. (2011). Corporate governance and corporate social responsibility: The moderating roles of attainment discrepancy and organization slack, *Corporate Governance: An International Review*, 19, 136–152
- Aust, I., Muller-Camen, M., & Poutsma, E. (2018). Sustainable HRM: A comparative and international perspective. In C. Brewster, E. Farndale, & W. Mayrhofer (Eds.), *Handbook of research in comparative human resource management* (2nd ed., 358 – 369). Cheltenham: Edward Elgar Publishing.
- Balluchi, F., & Furlotti, K. (2013). *CSR Disclosure by Italian Companies. An Empirical Analysis*. LAP Lambert Academic Publishing.
- Barr, P. S., Stimpert, J. L., & Huff, A. S. (1992). Cognitive Change, Strategic Action, and Organizational, *Strategic Management Journal*, 13, 15–36.
- Baselga-Pascual, L., Trujillo-Ponce, A., Vähämaa, E., & Vähämaa, S. (2018). Ethical Reputation of Financial Institutions: Do Board Characteristics Matter?, *Journal of Business Ethics*, 148(3), 489-510.
- ~~Bauman, Z. (1993). *Postmodern ethics*. Oxford: Blackwell.~~
- Baysinger, B. D., & Butler, H. N. (1985). Corporate Governance and the Board of Directors: Performance Effects of Changes in Board Composition, *Journal of Law, Economics, and Organization*, 1(1), 101–124.
- Barrena-Martínez, J., López-Fernández, M., Márquez-Moreno, C., & Romero-Fernández, P. M. (2015). Corporate social responsibility in the process of attracting college graduates. *Corporate Social Responsibility and Environmental Management*, 22(6), 408-423.

- Barrena-Martinez, J., López-Fernández, M., & Romero-Fernández, P. M. (2019). The link between socially responsible human resource management and intellectual capital. *Corporate Social Responsibility and Environmental Management*, 26, 71 – 81.
- Beasley, M. S. (1996). An Empirical Analysis of the Relation between the Board of Director Composition and Financial Statement Fraud, *The Accounting Review*, 71(4), 443–465.
- ~~Berenbeim, R. (2000). Global Ethics, Executive Excellence 17(5), 1-7.~~
- Berenbeim, R. E., & J. M. Kaplan (2004). Ethics Programs...The Role of the Board: A Global Study (Report R-1344, The Conference Board).
- Beyer, A., Cohen, D. A., Lys, T. Z., & Walther, B. R. (2010). The financial reporting environment: Review of the recent literature. *Journal of Accounting and Economics*, 50(2), 296-343.
- Bondy, K., D. Matten, & J. Moon (2004). The Adoption of Voluntary Codes of Conduct in MNCs: A Three-Country Comparative Study, *Business and Society Review* 109(4), 449–477.
- Bonn, I., & J. Fisher (2005). Corporate Governance and Business Ethics: Insights from the Strategic Planning Experience, *Corporate Governance: An International Review* 13(6), 730–738
- ~~Bowie, N. (1999). Business ethics: A Kantian perspective. Malden, MA: Blackwell.~~
- Campbell, T. (2006). A human rights approach to developing voluntary codes of conduct for multinational corporations, *Business Ethics Quarterly*, 16(2), 255-269.
- Campopiano, G., & De Massis, A. (2015). Corporate Social Responsibility Reporting: A Content Analysis in Family and Non-family Firms, *Journal of Business Ethics*, 129(3), 511–534.
- ~~Carasco, E.F., & Singh, J.B. (2003), 'The content and focus of the codes of ethics of the world's largest transnational corporations, *Business and Society Review*, Vol. 108 No. 1, 71-94.~~
- Celma, D., Martínez-García, E., & Coenders, G. (2014). Corporate social responsibility in human resource management: An analysis of common practices and their determinants in Spain. *Corporate Social Responsibility and Environmental Management*, 21(2), 82-99.

- Chau, G., & Gray, S. J. (2010). Family ownership, board independence and voluntary disclosure: Evidence from Hong Kong, *Journal of International Accounting, Auditing and Taxation*, 19(2), 93-109.
- Chaudhary, R. (2017). Demographic factors, personality and entrepreneurial inclination. *Education and Training*, 59(2), 171 – 187.
- Cheng, E. C. M., & Courtenay, S. M. (2006). Board composition, regulatory regime and voluntary disclosure, *International Journal of Accounting*, 41(3), 262–289.
- Chun, R. (2019). How virtuous global firms say they are: A content analysis of ethical values, *Journal of Business Ethics*, 155(1), 57-73.
- ~~Clegg, S., Kornberger, M., & Rhodes, C. (2007). Business ethics as practice, *British Journal of Management*, 18(2), 107-122.~~
- Cook, A., & Glass, C. (2016). Do women advance equity? The effect of gender leadership composition on LGBT-friendly policies in American firms, *Human relations*, 69(7), 1431-1456.
- Cook, A., & Glass, C. (2018). Women on corporate boards: Do they advance corporate social responsibility?, *Human Relations*, 71(7), 897-924.
- Dalton, D. A. N. R., Daily, C. M., Johnson, J. L., & Ellstrand, A. E. (1999). Number of Directors and Financial Performance: A Meta-Analysis, *Academy of Management Journal*, 42(6), 674–687.
- ~~De Villiers, C., Naiker, V., & Van Staden, C. J. (2011). The effect of board characteristics on firm environmental performance, *Journal of Management*, 37(6), 1636-1663.~~
- Dechow, P. M., Sloan, R. G., & Sweeney, A. P. (1995). Detecting Earnings Management, *The Accounting Review*, 70(2), 193–225.
- ~~Dechow, P. M., Sloan, R. G., & Sweeney, A. P. (1996). Causes and Consequences of Earnings Manipulation: An Analysis of Firms Subject to Enforcement Actions by the SEC, *Contemporary Accounting Research*, 13(1), 1–36.~~

- Dechow, P., Ge, W., & Schrand, C. (2010). Understanding Earnings Quality : A Review of Proxies, their Determinants and their Consequences Importance of Earnings Quality in Accounting Research, *Journal of Accounting and Economics*, 50(2–3), 344–401.
- DeFond, M. L., & Jiambalvo, J. (1994). Debt covenant violation and manipulation of accruals, *Journal of Accounting and Economics*, 17(1–2), 145–176.
- Diaz-Carrion R, López-Fernández M., & Romero-Fernandez P. M. (2020) Sustainable human resource management and employee engagement: A holistic assessment instrument. *Corporate Social Responsibility and Environmental Management*, 1 – 12.
- Dodge, K. A., & Rabiner, D. L. (2004). Returning to roots: On social information processing and moral development. *Child Development*, 75(4), 1003-1008.
- Donaldson, T., & Preston, L. E. E. E. (1995). The Stakeholder Theory of the Corporation: Concepts, Evidence and Implications, *Academy of Management Review*, 20(1), 65–91.
- Donnelly, R., & Mulcahy, M. (2008). Board structure, ownership, and voluntary disclosure in Ireland, *Corporate Governance: An International Review*, 16(5), 416-429.
- Duarte, A. P., Gomes, D. R., & das Neves, J. G. (2014). Tell me your socially responsible practices, I will tell you how attractive for recruitment you are! The impact of perceived CSR on organizational attractiveness. *Tékhne*, 12, 22-29.
- Eisenhardt, K. M. (1989). Agency theory: An assessment and review, *Academy of management review*, 14(1), 57-74.
- Farrukh, M., Sajid, M., Lee, J. W. C., & Shahzad, I. A. (2019). The perception of corporate social responsibility and employee engagement: Examining the underlying mechanism. *Corporate Social Responsibility and Environmental Management*, 26, 1 – 8.
- Ferrell, O.C., Harrison, D.E., Ferrell, L., & Hair, J.F. (2019), “Business ethics, corporate social responsibility, and brand attitudes: an exploratory study”, *Journal of Business Research*, Vol. 95, pp. 491-501.

- Fleeger, E., and Adrian, E. (2004). The implementation of corporate ethics: a comparative study between Motorola and Ericsson, *Journal of Undergraduate Research*, 7, 1-9.
- Fombrun, C. J., & Shanley, M. (1990). What's in a name? Reputation building and corporate strategy, *Academy of Management Journal*, 33, 233-258.
- Frias-Aceituno, J. V., Rodriguez-Ariza, L., & Garcia-Sanchez, I. M. (2013). The role of the board in the dissemination of integrated corporate social reporting, *Corporate Social Responsibility and Environmental Management*, 20(4), 219-233.
- Gamerschlag, R., Möller, K., & Verbeeten, F. (2011). Determinants of voluntary corporate social responsibility disclosure: Empirical evidence from Germany, *Review of Managerial Science*, 5(2), 233-262.
- Garcia-Sanchez, I. M., Cuadrado-Ballesteros, B., & Sepulveda, C. (2014). Does media pressures moderate corporate social responsibility disclosures by external directors? Evidence from listed Spanish companies, *Management Decision*, 52(6), 1014-1045.
- Garcia-Sanchez, I. M., Rodríguez-Domínguez, L., & Frías-Aceituno, J. V. (2015). Board of directors and ethics codes in different corporate governance systems, *Journal of Business Ethics*, 131(3), 681-698.
- Garcia-Sanchez, I. M., Rodriguez-Dominguez, L., & Gallego- Alvarez, I. (2011). Corporate governance and strategic information on the internet, *Accounting, Auditing and Accountability Journal*, 24(4), 471-501.
- Garegnani, G. M., Merlotti, E. P., & Russo, A. (2015). Scoring firms' codes of ethics: An explorative study of quality drivers, *Journal of Business Ethics*, 126(4), 541-557.
- Hansen, S. D., Dunford, B. B., Boss, A. D., Boss, R. W., & Angermeier, I. (2011). Corporate Social Responsibility and the Benefits of Employee Trust: A Cross-Disciplinary Perspective, *Journal of Business Ethics*, 102(1), 29-45.

- Harrison, D. E., Ferrell, O. C., Ferrell, L., & Hair Jr, J. F. (2019). Corporate social responsibility and business ethics: conceptualization, scale development and validation. *Journal of Product & Brand Management*, Vol. ahead-of-print No. ahead-of-print.
- Healy, P. M., & Palepu, K. G. (2001). Information asymmetry, corporate disclosure, and the capital markets: A review of the empirical disclosure literature, *Journal of Accounting and Economics*, 31(1-3), 405-440.
- Heidrick, & Struggles, (2004), 'Assuring Ethical and Responsible Leadership: How to Meet the Challenge, Lore International Institute, Neisendorf & Associates.
- Helfen, M., Schübler, E., & Sydow, J. (2018). How can employment relations in global value networks be managed towards social responsibility?, *Human Relations*, 71(12), 1640-1665.
- ~~Hillman, A. J., & Dalziel, T. (2003). Boards of directors and firm performance: Integrating agency and resource dependence perspectives, *Academy of Management review*, 28(3), 383-396.~~
- ~~Hirschman, A. O. (1970). Exit, voice, and loyalty: Responses to decline in firms, organizations, and states. Cambridge, MA: Harvard University Press.~~
- ~~Hsieh, N. H. (2006). Voluntary codes of conduct for multinational corporations: Coordinating duties of rescue and justice, *Business Ethics Quarterly*, 16(2), 119-135.~~
- Ibrahim, N. A., & Angelidis, J. P. (1995). The corporate social responsiveness orientation of board members: Are there differences between inside and outside directors?, *Journal of Business Ethics*, 14, 405-410.
- Jamali, D. R., El Dirani, A. M., & Harwood, I. A. (2015). Exploring human resource management roles in corporate social responsibility: The CSR-HRM co-creation model. *Business Ethics: A European Review*, 24, 125 – 143.
- Jensen, M. C. (2001). Value maximization, stakeholder theory, and the corporate objective function, *Journal of Applied Corporate Finance*, 14(3), 8-22.
- Jensen, M. C., & Meckling, W. H. (1976). Theory of the firm: Managerial behavior, agency costs and ownership structure, *Journal of financial economics*, 3(4), 305-360.

- Jiraporn, P., Potosky, D., & Lee, S. M. (2019). Corporate governance and lesbian, gay, bisexual, and transgender-supportive human resource policies from corporate social responsibility, resource-based, and agency perspectives, *Human Resource Management*, 58(3), 317-336.
- John, K., & Senbet, L. W. (1998). Corporate governance and board effectiveness, *Journal of Banking and Finance*, 22(4), 371-403.
- Johnson, R. A., & Greening, D. W. (1999). The effects of corporate governance and institutional ownership types on corporate social performance, *Academy of Management Journal*, 42, 564–576
- ~~Jones, C. (2003). As if business, ethics were possible, ‘within such limits’... . *Organization*, 10(2), 223–248.~~
- Jones, I., & M. Pollitt (1999). The Development of Ethical Issues Facing Boards of Directors: A Model with Implications’ (Working Paper No. 151, ESRC Centre for Business Research, University of Cambridge)
- ~~Kaptein, M. (2008). *The living code: Embedding ethics into the corporate DNA*. Sheffield: Greenleaf.~~
- Kaptein, M., & Schwartz, M. S. (2008). The effectiveness of business codes: A critical examination of existing studies and the development of an integrated research model, *Journal of Business Ethics*, 77, 111–127.
- Kim, C. H., & Scullion, H. (2013). The effect of Corporate Social Responsibility (CSR) on employee motivation: A cross-national study. *Poznan university of economics review*, 13(2).
- Klein, A. (2002). Audit committee, board of director characteristics, and earnings management, *Journal of Accounting and Economics*, 33(3), 375–400.
- Li, J., Pike, R., & Haniffa, R. (2008). Intellectual capital disclosure and corporate governance structure in UK firms, *Accounting and Business Research*, 38, 137–159
- Liao, P. C., Shih, Y. N., Wu, C. L., Zhang, X. L., & Wang, Y. (2018). Does corporate social performance pay back quickly? A longitudinal content analysis on international contractors, *Journal of Cleaner Production*, 170, 1328–1337.

- Liu, Q., & Lu, Z. J. (2007). Corporate governance and earnings management in the Chinese listed companies : A tunneling perspective, *Journal of Corporate Finance*, 13, 881–906.
- Lo, A., Wong, R., & Firth, M. (2010). Can corporate governance deter management from manipulating earnings ? Evidence from related-party sales transactions in China, *Journal of Corporate Finance*, 16(2), 225–235.
- Manley, W. (1991). Executive’s Handbook of Model Business Conduct Codes. Prentice-Hall, New York.
- Marchington M., & T. Dundon (2017). The challenges to fair voice, In D. Grimshaw, C. Fagan, G. Heb-son, & I. Távora (eds), *Making Work More Equal: A New Labour Market Segmentation Ap-proach*, 90–107. Manchester: Manchester University Press.
- Martínez-García, E., Sorribes, J., & Celma, D. (2018). Sustainable development through CSR in human resource management practices: The effects of the economic crisis on job quality. *Corporate So-cial Responsibility and Environmental Management*, 25, 441 – 456.
- Mason, C., & Simmons, J. (2013). Giving as good as they get? Organization and employee expectations of ethical business practice. *Business and Society Review*, 118(1), 47-70.
- Matten, D., & Crane, A. (2005). Corporate Citizenship: Toward an Extended Theoretical Conceptualiza-tion, *Academy of Management Review*, 30(1), 166–179.
- Molander, E. A. (1987). A paradigm for design, promulgation and enforcement of ethical codes, *Journal of Business Ethics*, 6(8), 619–631.
- ~~Morrison, E. and F. Milliken (2003). Speaking up, remaining silent: the dynamics of voice and silence in organizations, *Journal of Management Studies*, 40, 1353–1358.~~
- Neuendorf, K. A. (2002). *The content analysis guidebook*. London: Sage.
- Ng, W., & Roberts, J. (2007). ‘Helping the family’: The mediating role of outside directors in ethnic Chi-nese family firms, *Human Relations*, 60(2), 285-314.
- O’Dwyer, B., & G. Madden (2006), ‘Ethical Codes of Conduct in Irish Companies: A Survey of Code Content and Enforcement Procedures, *Journal of Business Ethics* 63(3), 217–236.

- Painter-Morland, M. (2010). Questioning corporate codes of ethics, *Business Ethics: A European Review*, 19(3), 265-279.
- Pathan, S. (2009). Strong boards, CEO power and bank risk-taking, *Journal of Banking and Finance*, 33(7), 1340-1350.
- Patton, A., & Baker, J. C. (1987). Why wont directors rock the boat, *Harvard Business Review*, 65(6), 1-10.
- ~~Payne, D., Raiborn C., & J. Askvik (1997), 'A Global Code of Business Ethics, *Journal of Business Ethics*, 16, 1727-1735.~~
- Pearce, J. A., & Zahra, S. A. (1992). Board Composition from a Strategic Contingency Perspective, *Journal of Management Studies*, 29(4), 411-438.
- Pedersen, E. R. G. (2011). All animals are equal, but . . . : Management perceptions of stakeholder relationships and societal responsibilities in multinational corporations, *Business Ethics*, 20(2), 177-191.
- Potter, W. J., & Levine-Donnerstein, D. (1999). Rethinking validity and reliability in content analysis, *Journal of Applied Communication Research*, 27(3), 258-284.
- Prado-Lorenzo, J. M., & García-Sánchez, I. M. (2010). The role of the board of directors in disseminating relevant information on greenhouse gases, *Journal of Business Ethics*, 97, 391-424.
- Pratt, M. G., Rockmann, K. W., & Kaufmann, J. B. (2006). Constructing Professional Identity: The Role of Work and Identity Learning Cycles in the Customization of Identity among Medical Residents, *The Academy of Management Journal*, 49(2), 235-262.
- Preuss, L., Barkemeyer, R., & Glavas, A. (2016). Corporate social responsibility in developing country multinationals: identifying company and country-level influences, *Business Ethics Quarterly*, 26(3), 347-378.
- Rodriguez-Dominguez, L., Gallego-Alvarez, I., & Garcia-Sanchez, I. M. (2009). Corporate governance and codes of ethics, *Journal of Business Ethics*, 90(2), 187.

- Rupp, D. E., Shao, R., Skarlicki, D. P., Paddock, E. L., Kim, T. Y., & Nadisic, T. (2018). Corporate social responsibility and employee engagement: The moderating role of CSR - specific relative autonomy and individualism. *Journal of Organizational Behavior*, 39(5), 559 – 579.
- Salancik, G. R., & Pfeffer, J. (1978). A social information processing approach to job attitudes and task design, *Administrative Science Quarterly*, 23, 224 – 253.
- Schwartz, M. S. (2002), 'A Code of Ethics for Corporate Code of Ethics, *Journal of Business Ethics* 41(1/2), 27–43.
- ~~Schwartz, M. S. and A. B. Carroll (2003). Corporate Social Responsibility: A Three Domain Approach, *Business Ethics Quarterly* 13, 503–530~~
- Shen, J., & Benson, J. (2016). When CSR is a social norm: How socially responsible human resource management affects employee work behavior. *Journal of Management*, 42, 1723 – 1746.
- Sobczak, A. (2006). Are codes of conduct in global supply chains really voluntary? From soft law regulation of labour relations to consumer law, *Business Ethics Quarterly*, 16(2), 167-184.
- Spiller, R. (2000). Ethical Business and Investment: A Model for Business and Society, *Journal of Business Ethics*, 27(1/2), 149–160.
- ~~Stevens, B. (1994). An Analysis of Corporate Ethical Codes Studies: Where do we go from here?, *Journal of Business Ethics*, 30(2), 63–69.~~
- ~~Stevens, B. (2004). The Ethics of the US Business Executive: A Study of Perceptions, *Journal Business Ethics*, 54, 163–171.~~
- Story, J., & Neves, P. (2015). When Corporate Social Responsibility (CSR) Increases Performance: Exploring the Role of Intrinsic and Extrinsic CSR Attribution, *Business Ethics: A European Review*, 24(2), 111–124.
- ~~Tourish, D., R. Craig and J. Amernic (2010). Transformational leadership education and agency perspectives in business school pedagogy: a marriage of inconvenience?' *British Journal of Management*, 21, 40–59.~~

- Tsui-Auch, L. S. (2004). The Professionally Managed Family-ruled Enterprise: Ethnic Chinese Business in Singapore, *Journal of Management Studies*, 41(1), 693–723.
- Tuggle, C. S., Sirmon, D. G., Reutzell, C. R., & Bierman, L. (2010). Commanding board of director attention: investigating how organizational performance and CEO duality affect board members' attention to monitoring, *Strategic Management Journal*, 31(9), 946-968.
- Vlachos, P. A., Panagopoulos, N. G., & Rapp, A. A. (2013). Feeling Good by Doing Good: Employee Corporate Social Responsibility -Induced Attributions, Job Satisfaction, and the Role of Charismatic Leadership, *Journal of Business Ethics*, 118(3), 577–588.
- Vlachos, P. A., Theotokis, A., & Panagopoulos, N. G. (2010). Sales force reactions to corporate social responsibility: Attributions, outcomes, and the mediating role of organizational trust, *Industrial Marketing Management*, 39(7), 1207–1218.
- Walumbwa, F. O., Hsu, I. C., Wu, C., Misati, E., & Christensen-Salem, A. (2019). Employee service performance and collective turnover: Examining the influence of initiating structure leadership, service climate and meaningfulness, *Human Relations*, 72(7), 1131-1153.
- Weaver, G. R. (1993). Corporate codes of ethics: Purpose, process and content issues, *Business and Society*, 32(1), 44–58.
- Welford, R. (2007). Corporate governance and corporate social responsibility: Issues for Asia. *Corporate Social Responsibility and Environmental Management*, 14, 42 – 51.
- Williams O.F., & Murphy P.E. (1990). The ethics of virtue: A moral theory for marketing, *Journal of Macromarketing*, Spring: 19-29.
- ~~Wood, G. (2002). A partnership model of corporate ethics, *Journal of Business Ethics*, 40(1), 61–73.~~
- Yang, F., Huang, X., & Wu, L. (2019). Experiencing meaningfulness climate in teams: How spiritual leadership enhances team effectiveness when facing uncertain tasks, *Human Resource Management*, 58(2), 155-168.
- Yeh, Y., Shu, P., & Su, Y. (2012). Related-party transactions and corporate governance: The evidence from the Taiwan stock market, *Pacific-Basin Finance Journal*, 20(5), 755–776

- Young, S., & Thyil, V. (2009). Governance, employees & CSR: Integration is the key to unlocking value. *Asia Pacific Journal of Human Resources*, 47(2), 167-185.
- Pedersen, E. R. G. (2011). All animals are equal, but...: management perceptions of stakeholder relationships and societal responsibilities in multinational corporations. *Business Ethics: A European Review*, 20(2), 177-191.
- Mazza, T., & Furlotti, K. (2019). Quality of code of ethics: an empirical analysis on the stakeholder employee. *Social Responsibility Journal*.

Figure 1. Theoretical model

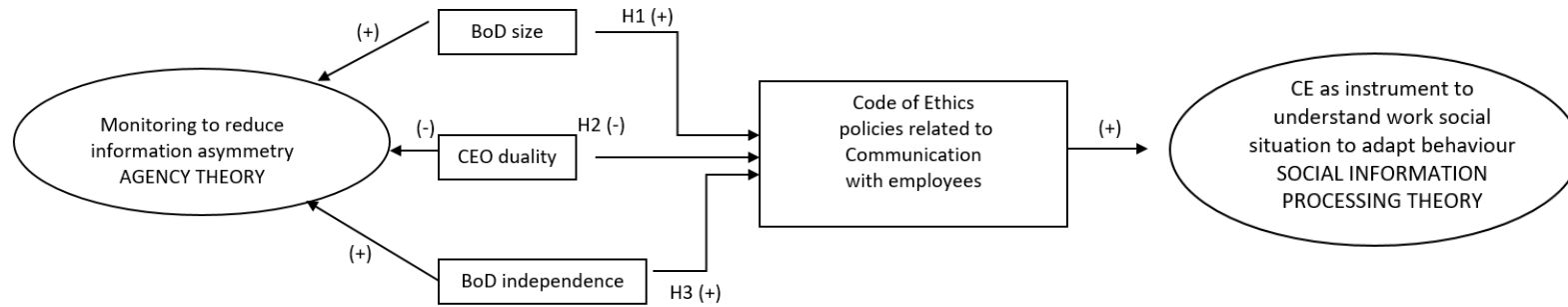

Legend

- Relation with policies related to implementation of company’s communication tools toward employees
- Theories
- Operationalized variables used in the regression model
- () Sign of expected relations

Acronyms: BoD – Board of Directors, CEO – Chief Executive Officer, CE – Code of Ethic

Table 1. Variable Definitions

CE policies related to communication with employees = 0, 1, 2, 3 or 4 if there are respectively 0, 1, 2, 3 or 4 of the following keywords:				
Level	Italian keywords	English translation of keywords	Explanation of the levels	Name of the variables
0	No keywords	No keywords	The code of ethic does not disclose any information about policies related to communication, even general communication	No general communication
1	“comunicazione/trasparenza/ fornire informazioni” AND “tutti stakeholders”	“communication/transparency/provide information” AND “all stakeholders”	Policies related to general communication with stakeholders but not specific communication with employees	No specific communication with employees
2	“comunicazione/trasparenza/ fornire informazioni” AND “tutti stakeholders” “rappresentante/responsabile” “sviluppo di particolari strumenti di comunicazione”	“communication/transparency/provide information” AND “all stakeholders” “representative/responsible”; “development of particular communication tools”	Policies related to general communication with stakeholders but not specific communication with employees AND policies to set up communication tools	No specific communication with employees with communication tools
3	“comunicazione/trasparenza/ fornire informazioni” AND “coinvolgimento del personale/dei dipendenti”; “disagio lavorativo”	“communication/transparency/provide information” AND “staff/employee involvement” “work discomfort”	Policies related to specific communication with employees	Specific communication with employees
4	“comunicazione/trasparenza/ fornire informazioni” AND “coinvolgimento del personale/dei dipendenti”; “disagio lavorativo” “rappresentante/responsabile” “sviluppo di particolari strumenti di comunicazione”	“communication/transparency/provide information” AND “staff/employee involvement” “work discomfort” “representative/responsible”; “development of particular communication tools”	Policies related to specific communication with employees AND policies to set up communication tools	Specific communication with employees with communication tools

Corporate governance	
<i>BoD Size</i>	Number of member of the board of directors
<i>CEO Duality</i>	Dummy variable 1 if CEO is also the BoD Chairman, 0 otherwise
<i>BoD Independence</i>	Number of independent directors / Total number of members
Firms' characteristics	
Size	Natural logarithm of total assets at the end of the fiscal year
Loss	Dummy variable 1 if net income < 0, and 0 otherwise
CFO	Cash flow from operation / total assets
CATA	Current assets / total assets
Leverage	Long term debts/total assets
Sales growth	$(\text{Revenue}_t - \text{revenue}_{t-1})$ scaled by revenue_{t-1} for fiscal year t

Table 2. Panel A. Sample selection

Panel A - Sample Selection	
Description	N
Number of Italian companies non-financial listed at the Milan Stock Exchange	307
-Number of companies with missing financial statement data	-37
-Number of companies without a CE	-52
-Number of companies with no available data on corporate governance	-16
Number of companies in the final sample	202
Number of observations in the balanced final sample in the period 2013-2016	808

Table 1. Panel B. Sample description by industry

Industry – United States Standard Industry Classification Code 1 digit	N
1 - Mining and Construction	44
2 - Manufacturing (food, tobacco, textile, furniture, paper, chemical)	168
3 - Manufacturing (plastic, leather, glass, metal, machinery, equipment)	228
4 - Transportation, Communications, Electric, Gas and Sanitary service	184
5 - Trade	44
7 and 8 - Services	140

Table 3. Panel A. Descriptive Statistics

N=808	Mean	Std. Dev.	p25	Median	p75	Min	Max
CE							
“CE policies related to communication with employees”	0.817	0.828	0.000	1.000	1.000	0.000	4.000
Corporate Governance							
<i>BoD Size (number)</i>	9.046	2.790	7.000	9.000	11.000	2.000	24.000
<i>CEO Duality</i>	0.416	0.493	0.000	0.000	1.000	0.000	1.000
<i>BoD Independence (number)</i>	3.927	2.240	2.000	3.000	5.000	0.000	15.000
<i>BoD Independence (percentage)</i>	0.419	0.158	0.298	0.400	0.529	0.000	0.900
Firms characteristics							
Size	6.009	2.030	4.597	5.909	7.287	1.418	11.837
Loss	0.270	0.444	0.000	0.000	1.000	0.000	1.000
CFO	0.085	0.362	0.016	0.065	0.101	-0.244	0.651
CATA	0.470	0.218	0.289	0.457	0.646	0.062	0.995
Leverage	0.170	0.145	0.048	0.142	0.262	0.000	0.618
Sales growth	0.039	0.247	-0.045	0.013	0.093	-0.803	1.309

See Table 1 for variable definitions. Acronyms: BoD – Board of Directors, CEO – Chief Executive Officer, CE – Code of Ethic, CFO – Cash Flow from Operation, CATA – current assets divided by total assets, Std. Dev. – standard deviation, p25 – 25 percent percentile, p75 – 75 percent percentile, Min – minimum, Max – maximum, N – number of observations

Table 3. Panel B. Distribution of CE variables

Level code	“Code of Ethic policies related to communication with employees”	Number of observations
0	No general comm.	300
1	No specific comm. with employees	412
2	No specific comm. with employees with communication tools	48
3	Specific comm. with employees	40
4	Specific comm. with employees with communication tools	8

Table 4. Correlation matrix

Variables	1	2	3	4	5	6	7	8	9	10
1 “CE policies related to communication with employees”	1.000									
2 <i>BoD Size</i>	0.071	1.000								
3 <i>CEO Duality</i>	-0.008	-0.281	1.000							
4 <i>BoD Independence</i>	0.165	0.308	-0.201	1.000						
5 Size	0.092	0.520	-0.287	0.441	1.000					
6 Loss	-0.017	-0.036	0.030	0.108	-0.135	1.000				
7 CFO	-0.024	0.035	-0.052	0.031	-0.071	-0.135	1.000			
8 CATA	-0.124	-0.248	0.145	-0.197	-0.284	-0.037	-0.132	1.000		
9 Leverage	0.197	0.185	-0.044	0.183	0.275	0.014	0.050	-0.450	1.000	
10 Sales growth	-0.064	-0.065	0.071	-0.161	-0.087	-0.150	0.021	0.017	0.019	1.000

Pearson correlation coefficients significant at 5 percent in **bold**.

See Table 1 for variable definitions. Acronyms: BoD – Board of Directors, CEO – Chief Executive Officer, CE – Code of Ethic, CFO – Cash Flow from Operation, CATA – current assets divided by total assets.

Table 5. Regressions.

CE policies related to communication with employees	Model 1		Model 2		Model 3	
	Estimate	p-value	Estimate	p-value	Estimate	p-value
<i>BoD Size</i>	-0.006	0.737				
<i>CEO Duality</i>			0.089	0.341		
<i>BoD Independence</i>					0.977	0.002
Size	0.054	0.018	0.057	0.011	0.018	0.411
Loss	-0.100	0.290	-0.102	0.281	-0.159	0.110
CFO	-0.199	0.063	-0.195	0.063	-0.214	0.052
CATA	0.317	0.175	0.319	0.171	0.335	0.152
Leverage	0.945	0.005	0.926	0.006	0.944	0.006
Sales growth	-0.303	0.080	-0.311	0.074	-0.235	0.182
Industry fixed effect	included		included		included	
N		808		808		808
Adj. R2		0.100		0.102		0.114

See Table 1 for variable definitions. Ordered probit regressions with robust standard errors.

Acronyms: BoD – Board of Directors, CEO – Chief Executive Officer, CE – Code of Ethic, CFO – Cash Flow from Operation, CATA – current assets divided by total assets, N – number of observations, Adj. R2 – adjusted R square

Appendix

Example of disclosure in the CE for “CE policies related to communication with employees”

Level	Example
LEVEL 1	<p>“Communication”, p.7, Infrastrutture Wireless, 2017, https://www.inwit.it/governance/sistema-di-governance/codice-etico “We guarantee the transparency of our action and our communications in relations with all stakeholders, in safeguarding the confidentiality requirements required by the conduct of the business.”</p>
LEVEL 2	<p>“Transparency”, p.18, Best Union, 2015, http://www.bestunion.it/wp-content/uploads/tmp/Codice-Etico-Best-Union.pdf “The Company believes in the value of transparency and is committed to managing relations with the stakeholders by providing true, complete and clear information, thereby encouraging informed action and sharing of knowledge. Staff management policies are made available to all collaborators through corporate communication tools developed within the organization.”</p>
LEVEL 3	<p>“Relationships with employees and collaborators”, p.12, Arnoldo Mondadori, 2013, http://www.mondadori.it/governance/etica-e-comportamento/codice-etico “Furthermore, the Group takes care to avoid stress and, in general, work discomfort, also through communication.”</p>
LEVEL 4	<p>“Involvement of employees and collaborators”, p. 34, Hera, 2016, http://www.gruppohera.it/binary/hr_gruppo/preamboli/2014_03_12_HERA_CODICE_ETICO.1396004963.pdf “Hera, starting from their responsible, promotes a work environment based on information, transparency and involvement of the staff. In particular, Hera develops appropriate corporate's communication tools.””</p>