



UNIVERSITÀ DI PARMA

ARCHIVIO DELLA RICERCA

University of Parma Research Repository

Water cold plates for high power converters: A software tool for easy optimized design

This is the peer reviewed version of the following article:

Original

Water cold plates for high power converters: A software tool for easy optimized design / Cova, P.; Delmonte, N.; Chiozzi, D.; Portesine, M.; Vaccaro, F.; Mantegazza, E.. - In: MICROELECTRONICS RELIABILITY. - ISSN 0026-2714. - 88-90:(2018), pp. 801-805. [[10.1016/j.microrel.2018.06.050](https://doi.org/10.1016/j.microrel.2018.06.050)]

Availability:

This version is available at: 11381/2850720 since: 2022-01-20T19:55:21Z

Publisher:

Published

DOI:[10.1016/j.microrel.2018.06.050](https://doi.org/10.1016/j.microrel.2018.06.050)

Terms of use:

Anyone can freely access the full text of works made available as "Open Access". Works made available

Publisher copyright

note finali coverpage

(Article begins on next page)

02 May 2026

Water cold plates for high power converters: a software tool for easy optimized design

P. Cova^{a,*}, N. Delmonte^a, D. Chiozzi,
M. Portesine^b, F. Vaccaro^b, E. Mantegazza^b

^a *Dipartimento di Ingegneria e Architettura, University of Parma, Parma, Italy*

^b *POSEICO S.p.A., Genova, Italy*

Abstract

This work proposes a SPICE-CFD/FEM based methodology for an optimized design of water heatsinks for high power electronic converters. Cold plates are a key issue for power electronics systems, in order to obtain reliable applications. Often the design of custom heatsinks is done by manual procedures, which require the fabrication of several prototypes. On the other hand, CFD+FEM analysis is a powerful tool to design optimized cold plates, but it requires skilled technicians and long simulation studies.

In this paper a SPICE based methodology, with negligible simulation cost and limited use of CFD+FEM simulations and prototypes, is demonstrated to be adequate to design cold plates with the lowest thermal resistance and the lowest surface temperature gradient.

A prototype made with the proposed methodology was used to validate the approach. Results show a good agreement between cold plate thermal-fluid dynamic 3D numerical simulations and the SPICE based methodology.

A software tool was developed to easily exploit the proposed methodology in customized design of cold plates for any specific application, and to extract necessary data for the datasheet: pressure drop, and thermal resistance.

1. Introduction

Thermal management is nowadays the main bottleneck in power systems design. Water heatsinks are a key issue in power electronics systems, in order to develop reliable applications. Optimization of water cold plates is an important task, in order to guarantee temperature uniformity on power devices and modules, which is a reliability key issue. Often, customized heatsinks are designed by manual procedures, which require the fabrication of several prototypes, to get the best solution [1], [2]. Otherwise, Finite Element Method (FEM) analysis can be used. Fig. 1 shows, as an example, the 3D model of a cold plate with four IGBT modules mounted on it.

When the layout of power devices to cool is known, the cold plate can be customized and optimized with Thermal-Computational Fluid-

Dynamic simulations, but this requires skilled staff, large amount of computational resources, and long simulation time [3-5]. Here, a methodology to design optimized cold plates with low cost, and limited use of CFD+FEM simulations and prototypes is

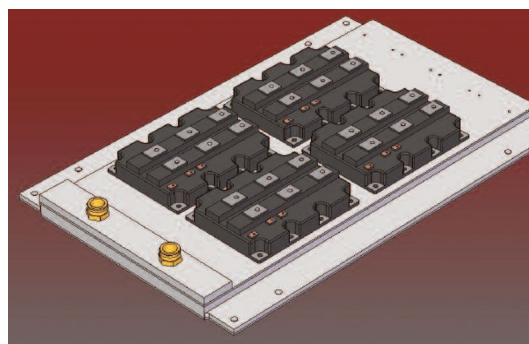

Fig. 1. 3D model of a cold plate with four IGBT modules mounted on it.

proposed. CFD+FEM simulations are needed only in the first auto-learning stage.

At the end, the developed methodology:

- i) allows to obtain optimized solutions in a very short time;
- ii) requires a very small amount of computational resources;
- iii) provides a tool that does not need any expertise in FEM or CFD analysis. Then, as final result of this work, a software tool was developed to allow power device companies and final users for the exploitation of this methodology.

To verify the accuracy of the developed software, a comparison with results of 3D CFD+Heat Transfer FEM simulations was carried out. Although this should be sufficient to validate the proposed methodology and the developed software, thermal measurements performed on a first prototype to validate the 3D numerical model are also shown in the paper.

Section 2 describes the *3D numerical* -SPICE proposed methodology and the software tool developed for its implementation. In Section 3 the prototype used for the *3D numerical* modeling validation is shown, together with the results of thermal and fluid-dynamic characterization. In Section 4 a real case study is reported, to show an example of exploitation of the proposed *3D numerical* -SPICE design procedure.

2. The 3D numerical -SPICE methodology

A library was created by the commercial platform COMSOL Multiphysics, with the aim of enabling quick and easy thermal-fluid dynamic simulations of cold plate on which electronic power devices (usually IGBT modules or diodes) are mounted. This library allows to create cold plates with different form factors, combining elementary elements.

It is assumed that the cold plate is made of bulk aluminum, in which water flows through grooves, whose shape can be composed by the following basic elements: i) serpentine; ii) straights; iii) curves; iv) junctions. The developed software uses the electro-fluid dynamic equivalence to calculate the pressure drop, according to the flow rate and the geometry of the grooves, while using a dataset built through FEM simulations to calculate the surface temperature.

According to the flow rate and the power dissipated by the overlying components, a thermal basic element is made. Each element is modeled through a SPICE library, which implements a

subcircuit that can be solved through any SPICE simulator. Therefore, it allows to simulate any cold plate configuration, provided that the construction rules and the validity limits are respected for every element. Fig. 2 shows a block diagram of the SPICE-CFD/FEM proposed approach, while Fig. 3 illustrates the flow diagram of the developed software tool. The bottom diagram of Fig. 2, represents a model of a simple cold plate made of an

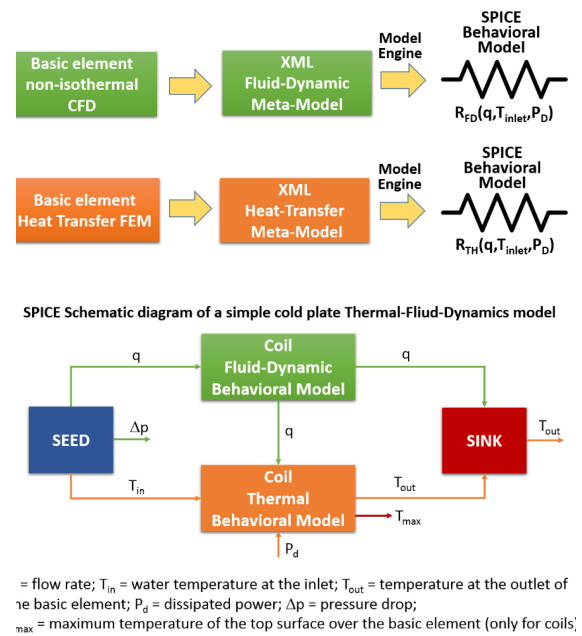

Fig. 2. Schematic diagram of the 3D numerical-SPICE approach for thermo-fluid dynamic simulation of cold plates: (top) basic elements from 3D numerical model to SPICE model transform process; (bottom) SPICE schematic of a simple cold plate.

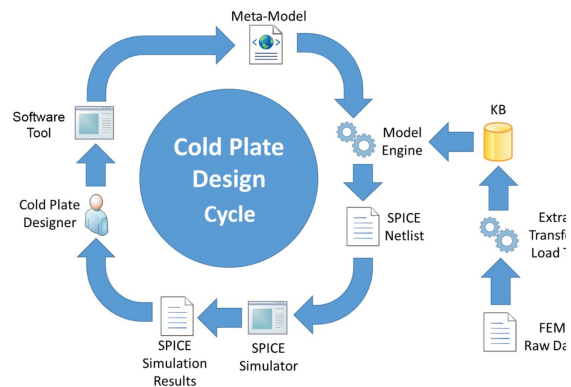

Fig. 3. Flow diagram of the software tool developed to easily exploit the SPICE-CFD/FEM proposed approach for optimized cold plate design.

inlet (called “seed” in this model), a water cooling path shaped as a coil, and an outlet (called “sink” in this model). Setting the pressure at the outlet equal to 0, the total pressure drop Δp coincides with the resulting pressure at the inlet.

A cold plate can be seen as composed by basic elements, linked between them through fluid-dynamic relationships. Only selected elementary parts were simulated through CFD/FEM and a Knowledge Base (KB) was built. A Meta-Model (an XML file in this case) is used to describe the structure of the basic elements composing the cold plate, and to initialize the inputs. Starting from this Meta-Model, and taking data from the KB, the Model Engine, builds the behavioral model of each basic element with the SPICE syntax. The final model is a SPICE netlist composed the behavioral models of the basic elements.

For example, Fig. 4 shows the XML script describing a cold plate composed by three basic elements: a seed (the cold plate inlet), a coil (the part for the heat removal of a power module mounted on the cold plate), and a sink (the cold plate outlet).

```

<coldplate>
  <part>
    <id>1</id>
    <type>SEED</type>
    <flowrate>
      <value>12</value>
      <unit>(10^3*m^3)/(60*s)</unit>
    </flowrate>
    <flowtemperature>
      <value>293.15</value>
      <unit>K</unit>
    </flowtemperature>
  </part>
  <part>
    <id>2</id>
    <type>COIL</type>
    <model>POSEICO_1</model>
    <powerdissipation>
      <value>2000</value>
      <unit>(10^3*g)*(m^2)*(s^3)</unit>
    </powerdissipation>
  </part>
  <part>
    <id>3</id>
    <type>SINK</type>
  </part>
  <node>
    <id>1</id>
    <from>1</from>
    <to>2</to>
  </node>
  <node>
    <id>2</id>
    <from>1</from>
    <to>3</to>
  </node>
</coldplate>

```

Fig. 4. Meta-Model (in XML) of a simple cold plate with an inlet (SEED), an outlet (SINK) and a serpentine (COIL).

3. CFD/FEM model validation and first design

First of all, the fluid-dynamic FEM was tuned by measurements on a first simple prototype (called testing cold plate in the following) fabricated ad-hoc by POSEICO: pressure drop between water inlet and outlet, measured at different flow rates, was used.

Secondly the thermo-fluid-dynamic FEM model of the testing cold plate was validated by measurements, following the same procedure described in [6], with the test bench of Fig. 5.

The lower surface of the cold plate was heated by power resistors, while the upper one was exposed to the air and its temperature was acquired by thermocouples and an IR-camera.

Surface temperatures and water outlet temperature were acquired at different values of dissipated power and flow rate, and a good agreement was reached. Fig. 6 shows the comparison between the cold plate surface temperature measured and simulated, with the same condition of dissipated power, water temperature, and flow rate: the error was lower than 1 °C, over the whole surface. Further details about the model validation process are reported in [6].

By the FEM model, complex cold plates, used for high power system cooling, were analyzed, to find possible weaknesses and improve the layout. Fig. 7 shows, as an example, the thermal map of a first design of cold plate for high power application, sinking a total power of 9100 W, distributed on 4 IGBT modules, with a water flow rate of 12 l/min. This cold plate was designed with internal coils placed below the footprint of the heating devices.

The water temperature was 20 °C at the inlet (in the center of the cold plate) and 30 °C at the outlet

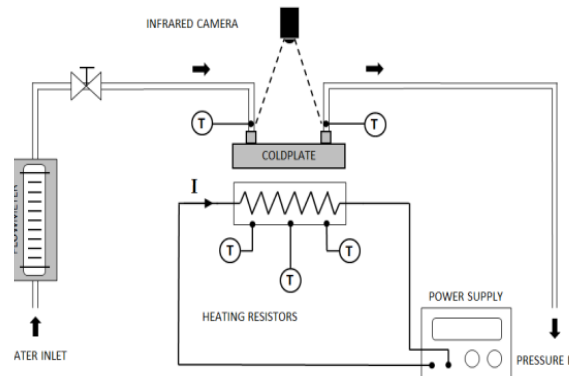

Fig. 5. Schematic of the experimental set-up used for the thermal characterization of the testing cold plate used for CFD-FEM model validation.

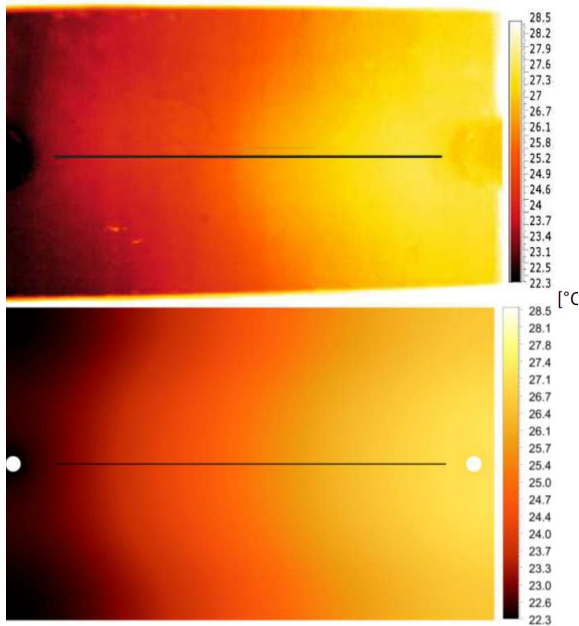

Fig. 6. Testing cold plate surface temperature map measured by IR camera (top) and simulated by the CFD-FEM model (bottom).

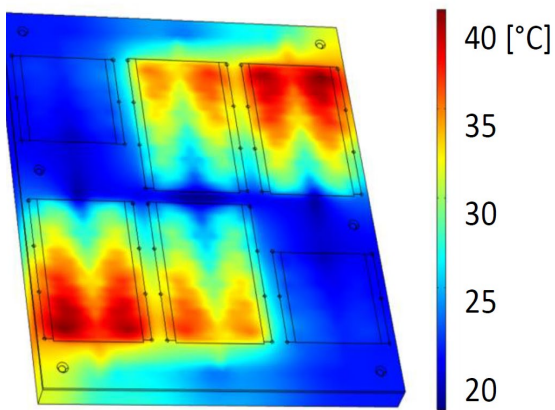

Fig. 7. FEM thermal map for the first design of cold plate for power application, with an input power of 9.1 kW, from 4 IGBT, flow rate of 12 l/min, and inlet water temperature of 20 °C.

(in two opposite corners of the cold plate). Even though the four IGBTs are dissipating the same power of 2275 W, a significant temperature gradient appears on the cold plate surface, meaning that the coolant's paths were not optimized for this specific application.

4. SPICE-CFD/FEM design procedure exploitation

The SPICE proposed approach, was firstly validated by comparison with CFD/FEM simulation of the prototype. Fig. 8 shows the equivalent SPICE circuit for the prototype of Fig. 7, while the main results of the comparison are reported in Tab. 1, together with the results obtained with different values of total dissipated power (6 kW, 9.1 kW, and 12 kW), showing that the agreement is good.

As can be seen here, only one value of the total pressure drop along the cold plate is shown, because, as already mentioned, the head losses are not significantly affected by the temperature increase of the cooling water. This is due to the fact that the temperature variation is not large enough to span over a non-linear region of the coolant fluid-dynamic parameters. 3D numerical simulations made with the Conjugate Heat Transfer module of COMSOL Multiphysics 5.3, confirm this behavior.

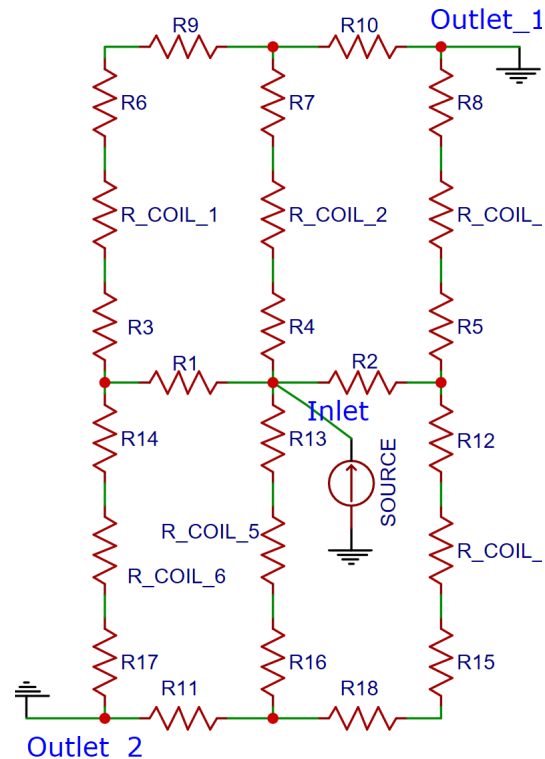

Fig. 8. SPICE equivalent model for the prototype of Fig. 7.

Table 1

Pressure drop and maximum surface temperature simulated for the prototype with input power of 6, 9.1, and 12 kW equally generated by four IGBT modules, water flow of 12 l/min, and inlet water temperature of 20 °C.

Parameter	3D numerical	SPICE
Δp [mbar]	20	23
T_{max} [°C] @ 6 kW	31	34
T_{max} [°C] @ 9.1 kW	38	42
T_{max} [°C] @ 12 kW	45	49

By applying the SPICE-CFD/FE software tool, different layout solutions were tested (also using parametric simulations), varying the section of the connecting grooves, in order to guarantee homogeneous fluid velocity below the heating modules. After the optimization procedure, which takes a computational load of few minutes in an ordinary PC, an optimized layout was found. As shown in Fig. 9, the thermal map of the cold plate simulated by CFD/FEM for the final structure, at the same conditions of Fig. 7, exhibits a much smaller temperature gradient, as well as a lower maximum temperature.

The measured thermal resistance of the cold plate, as usually defined in a cold plate datasheet by the maximum surface temperature increase (with respect to the water inlet temperature) divided by the total dissipated power, for instance at $P_d = 9$ kW, turned out:

$$R_{th} = \frac{T_{max} - T_{inlet}}{P_d} = 1.87 \text{ K/W}$$

By the proposed methodology POSEICO designed and manufactured an integrated cold plate (patent pending).

5. Conclusions

In this paper a SPICE-CFD/FEM methodology was presented for optimized design of water heatsinks for high power systems.

In order to validate the approach, a first prototype was accurately simulated through 3D numerical study, and the CFD/FEM model was validated by thermal characterization of the prototype.

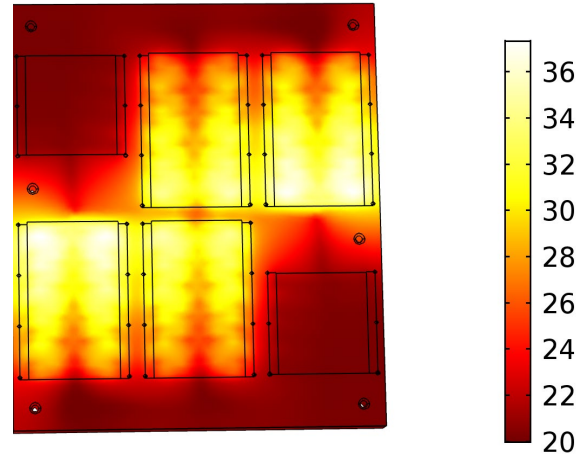

Fig. 9. FEM thermal map simulated after layout optimization by the CFD/FEM-SPICE software tool, for the prototype at the same conditions as in Fig. 7. Color temperature bar in °C.

The used case study was composed by different fundamental parts (i.e. coils, coupling straights, elbow nipples, etc.). CFD/FEM and SPICE results were compared in order to evaluate the agreement between the two simulation methodologies and to validate the approach. Results showed a good agreement between the thermo-fluid-dynamic 3D numerical simulation and the SPICE based methodology.

A software tool was built for an easy exploitation of this methodology on a common PC. It was demonstrated that the proposed method allows to design the best cold plate solution, saving simulation resources, and to extract necessary data for building a datasheet, i.e. pressure drop and thermal resistance.

Finally, POSEICO designed and developed a new integrated cold plate (patent pending), by using the proposed methodology.

Acknowledgements

This work was partly funded by Italian National project P.O.R. FESR LIGURIA 2014-2020 - Asse 1 "Ricerca e Innovazione (OT1)", Azione 1.1.3.

References

- [1] S.G. Kandlikar, C.N. Hayner II, "Liquid cooled cold plates for industrial high-power electronic devices -

- Thermal design and manufacturing considerations”, *Heat Transfer Engineering*, vol. 30: pp. 918-930, 2009.
- [2] J. Valenzuela, T. Jasinski, Z. Sheikh, “Liquid cooling for high-power electronics”, *Power Electronics Technology*, pp. 50-56, 2005.
- [3] P. Cova, N. Delmonte, F. Giuliani, M. Citterio, S. Latorre, M. Lazzaroni, A. Lanza, “Thermal optimization of water heat sink for power converters with tight thermal constraints”, *Microelectronics Reliability*, vol. 53, pp. 1760-1765, 2013.
- [4] T. Wang, B. Gua, P. Zhao, C. Qian, “Numerical investigation of liquid cooling cold plate for power control unit in fuel cell vehicle”, *Microelectronics Reliability*, vol. 55, pp. 1077-1088, 2015.
- [5] D. DeVoto, P. McCluskey, “Reliability modeling of a single phase liquid cooling system for power electronics applications”, *Proc. 12th IEEE Itherm*, Jun. 2-5, 2010.
- [6] M. Lazzaroni, M. Citterio, S. Latorre, A. Lanza, P. Cova, N. Delmonte, F. Giuliani, “Metrological characterization of cold plates for power converters”, *IEEE Transactions on Instrumentation and Measurement*, vol. 65, pp. 37-45, 2016.