



UNIVERSITÀ DI PARMA

ARCHIVIO DELLA RICERCA

University of Parma Research Repository

Space-learning tracking control for permanent magnet step motors

This is a pre print version of the following article:

Original

Space-learning tracking control for permanent magnet step motors / Verrelli, Cristiano Maria; Tomei, Patrizio; Consolini, Luca; Lorenzani, Emilio. - In: AUTOMATICA. - ISSN 0005-1098. - 73:(2016), pp. 223-230. [10.1016/j.automatica.2016.07.019]

Availability:

This version is available at: 11381/2816073 since: 2021-11-15T09:14:24Z

Publisher:

Elsevier Ltd

Published

DOI:10.1016/j.automatica.2016.07.019

Terms of use:

Anyone can freely access the full text of works made available as "Open Access". Works made available

Publisher copyright

note finali coverpage

(Article begins on next page)

02 May 2026

Space-Learning Tracking Control for Permanent Magnet Step Motors

Cristiano Maria Verrelli* Patrizio Tomei* Luca Consolini**
Emilio Lorenzani***

* *University of Rome Tor Vergata, Electronic Engineering Department,
Via del Politecnico 1, 00133 Rome, Italy, E-mails:
verrelli@ing.uniroma2.it, tomesi@ing.uniroma2.it.*

** *"Università di Parma", "Dipartimento di Ingegneria
dell'Informazione", Parco Area delle Scienze 181/A, 43124 Parma,
Italy, E-mail: lucac@ce.unipr.it.*

*** *"Università degli Studi di Modena e Reggio Emilia", Department of
"Scienze e Metodi dell'Ingegneria", Via Amendola 2, 42122 Reggio
Emilia, Italy, E-mail: emilio.lorenzani@unimore.it.*

Abstract: Repetitive space-learning controls are designed for current-fed uncertain permanent magnet step motors with non-sinusoidal flux distribution (the family of permanent magnet synchronous motors with cogging torque is allowed as a special case). Either semi-global rotor speed tracking is asymptotically achieved or local rotor position tracking is asymptotically guaranteed without requiring the time-periodicity of the corresponding reference signals. Simulation results illustrate the effectiveness of the presented approach in a typical electric drive control scenario, even in the presence of stator current dynamics which have been neglected at the design stage.

Keywords: Repetitive learning control, Space-learning, Step motor, Permanent magnet synchronous motor, Torque ripples, Cogging torque.

1. INTRODUCTION

Permanent magnet motors are used in a wide range of drive applications including machine tools and industrial robots: their high efficiency, high torque to inertia ratio, high power density, absence of rotor windings, absence of external rotor excitation constitute definite advantages. Hybrid stepper (permanent magnet) motors are generally operated in an open-loop fashion while being used for simple point-to-point positioning tasks: the performance is however degraded by speed oscillations/torque ripples which are related to the non-sinusoidal flux distribution in the air-gap. Even though improvements in motor design are effective in ripple minimization ([29]), production process complexity and machine costs increase so that compensation of torque pulsations by feedback actions becomes a rather effective solution ([14]). The use of feedback is particularly crucial in high-precision tracking control problems in which reference signals for the rotor position or speed are required to be precisely tracked in the presence of severe uncertainties in the motor dynamics ([40]). In this regard, adaptive control techniques can be generally applied to guarantee asymptotic tracking (see to this purpose [8], [29], [33]): uncertainties are, however, linearly parameterized and - in contrast to this paper - the involved number of uncertain coefficients (or at least an upper bound on this number) is required to be known (see the subsequent role played by the uncertain integer m in the motor model). Analogously, standard adaptive or extended-state observer-based controls (see for

instance [15], [19], [18], [27], [28], [34]) restrictively require the disturbances appearing in the rotor speed dynamics to be modeled by finite-dimensional linear or nonlinear exosystems of known dimension (see for instance [29] for the case of a well-designed permanent magnet synchronous motor with negligible reluctance and cogging torque). On the other hand, when the position reference signals are periodic with known period T_* (trivially including constant reference values), the undesirable uncertain disturbances become periodic with the same period T_* , so that classical (global) adaptive and repetitive learning control techniques apply (see [2], [12], [24], [25], [36], [38] for the fundamental ideas). They are successfully used in [7], [10], [24] (see [5] for experimental comparisons and discussions) to exponentially reduce or asymptotically annihilate the position tracking error in uncertain current-fed permanent magnet step motors (see [24] and [6] for theoretical extensions to full order model- permanent magnet step motors and [4], [13], [26], [30], [31], [35], [37] for experimental applications of standard iterative learning control techniques to torque and speed control in permanent magnet synchronous motors). The repetitive learning design problem is, however, yet to be solved in the presence of: i) a speed tracking problem with rotor speed reference signals $\theta^*(t)$ which are always greater than a positive constant value; ii) position tracking with rotor position reference signals $\theta^*(t)$ (as in [8]) which are strictly time-increasing and non time-periodic. Only partial solutions - in terms of theoretical validity - have been provided in [22], [23] in the case of simplified disturbance models (see also [3]

and [39] for related theoretical and implementation issues). The fact that a trial (in time) might be truncated early or late by events which depend on the state of the system is in fact a general limitation of (time-) learning controls requiring uniform trial time length (see [1], [9], [20], [32] and references therein).

The aim of this paper is to mathematically state and solve through recent repetitive learning control techniques the aforementioned rotor speed/position tracking problems for uncertain current-fed permanent magnet step motors when the load torque is a periodic function of the rotor position (constant load torques are allowed as simple degenerative cases). The family of permanent magnet synchronous motors with cogging torque are included as a special case. The key-idea of this paper relies on resorting to the recent theoretical developments in [11] while taking advantage, as in [22], [23], [33], from the position-periodic structure of the uncertain disturbance functions which holds in place of the aforementioned time-periodic one. The results in [22] and [23] are thus generalized: the rotor position reference signal $\theta^*(t)$ - and not the rotor position θ as in [22] and [23] - is here crucially involved in the key change of time scale, i.e. from t to $\theta^*(t)$. Semi-global asymptotic results are achieved in the case of the rotor speed tracking through a P type (proportional-type) learning control, while local asymptotic convergence properties are obtained in the case of the rotor position tracking through a PD type (proportional-derivative type) learning control. Anyway, both the control algorithms incorporate suitable repetitive space-learning estimation schemes, playing the role of asymptotically rejecting the effects of position-periodic disturbances, with the advantageous features of a classical robust controller being completely preserved as in [7]. The paper is organized as follows. The motor dynamic model is reported in Section 2. The rotor speed tracking problem is semi-globally solved in Section 3. A local solution to the rotor position tracking problem is presented in Section 4. Realistic simulation results are finally reported in Section 5: they illustrate the closed loop performance while showing the effectiveness of the proposed approach in a typical electric drive control scenario, even in the presence of stator current dynamics which have been neglected at the design stage.

2. DYNAMIC MODEL

The dynamics of a current-fed permanent magnet step motor with two phases in the (d, q) reference frame rotating at speed $N_r\omega$ and identified by the angle $N_r\theta$ in the fixed (a, b) reference frame attached to the stator [θ is the rotor position, ω is the rotor speed and N_r is the number of rotor teeth] are given by (see [16] and [7]) [$m \geq 4$ is any (uncertain) integer]

$$\begin{aligned} \frac{d\theta(t)}{dt} &= \omega(t) \\ \frac{d\omega(t)}{dt} &= -\frac{D}{J}\omega(t) + 2N_rL_1i_d(t)i_q(t) \\ &\quad + \frac{i_fN_r}{J} \sum_{j=1}^m jL_{mj} \cos[(1-j)N_r\theta(t)]i_q(t) \end{aligned}$$

$$\begin{aligned} &+ \frac{i_fN_r}{J} \sum_{j=2}^m jL_{mj} \sin[(1-j)N_r\theta(t)]i_d(t) \\ &- \frac{N_r i_f^2}{2J} \sum_{j=4}^m jL_{fj} \sin[jN_r\theta(t)] - \frac{T_L(\theta(t))}{J} \end{aligned}$$

where (i_d, i_q) are the stator current vector (d, q) components [which constitute the control inputs], D is the friction coefficient, J is the motor+load inertia, $T_L(\theta)$ is the load torque which is assumed to be θ -periodic with period $2\pi/k_l$ (k_l is a known positive integer)¹, i_f is the fictitious constant rotor current provided by the permanent magnet, L_1 is a non-negative parameter, the harmonics $L_{mj} \cos[jN_r\theta]$ and $L_{mj} \cos[jN_r\theta - \frac{\pi}{2}]$ model the non-sinusoidal flux distribution in the airgap, while the term $\frac{N_r i_f^2}{2} \sum_{j=4}^m jL_{fj} \sin[jN_r\theta]$ represents the disturbance torque due to cogging. The above model highlights the fact that geometric imperfections determine non-sinusoidal gap saliency so that inductances, in real motors, contain phase shifts and high order harmonics. The above current-fed model is obtained by neglecting the stator current dynamics and by allowing for $L_1 \neq 0$ in the full-order model of the permanent magnet step motor described in [17] and reported in Section 5. Its derivation involves the computational steps in [8] under the assumptions that: i) the magnetic field is linear with respect to the currents (that is no magnetic saturation occurs); ii) the self inductances and the mutual inductance of the two windings are constant with respect to θ . In practice, the parameters L_{mj} , $2 \leq j \leq m$ (which are zero under the standard assumption of sinusoidal flux distribution) are much smaller than L_{m1} (see for instance [17] and [8]), so that (for all $t \geq 0$) $\sum_{j=1}^m jL_{mj}c_j(t) = L_{m1} + \sum_{j=2}^m jL_{mj}c_j(t) \geq a_h > 0$ with $c_j(t) = \cos[(1-j)N_r\theta(t)]$. The previous motor model can be thus rewritten as²

$$\begin{aligned} \frac{d\theta(t)}{dt} &= \omega(t) \\ h(\theta(t)) \frac{d\omega(t)}{dt} &= -\alpha(\theta(t)) - \beta(\theta(t))\omega(t) + i_q(t) \\ &\quad + \chi(\theta(t), i_q(t), i_d(t)) \end{aligned} \quad (1)$$

with while

$$\begin{aligned} h(\theta) &= \frac{J}{i_fN_r} \left[\sum_{j=1}^m jL_{mj} \cos[(1-j)N_r\theta] \right]^{-1} \\ \alpha(\theta) &= \frac{h(\theta)}{J} \left[T_L(\theta) + \frac{N_r i_f^2}{2} \sum_{j=4}^m jL_{fj} \sin[jN_r\theta] \right] \\ \beta(\theta) &= \frac{Dh(\theta)}{J} \end{aligned}$$

¹ Even though position/speed dependent load torques $T_L(\theta, \omega)$ can be considered in general electric motor applications, this paper considers the wide family of positioning applications for permanent magnet step motors in which the load torque periodically depends on the rotor position. Constant load torques are trivially allowed.

² Model (1) even describes, in the rotating (d, q) reference frame, the dynamics of a permanent magnet synchronous motor with cogging torque, provided that the number of rotor teeth N_r is replaced by the number of pole pairs p . In this case, simplifications drastically occur with $\beta(\cdot)$ and $h(\cdot)$ simply reducing to positive constant values and $\alpha(\cdot)$ only describing the effect of load and cogging torques.

are uncertain functions (owing to the uncertainties in all system parameters), which are periodic with known period $T = 2\gamma\pi/N_r$ (γ is the minimum positive integer such that $\gamma k_i/N_r$ is a positive integer). The following assumptions (typically being satisfied in the practice) will be used in the subsequent sections. A.1) N_r is a known parameter; A.2) the function $\alpha(\theta)$ (namely $T_L(\theta)$) is of class \mathcal{C}^{s_α} ($s_\alpha \geq 2$); A.3) there exist known positive reals $h_m, h_M, k_h, k_{\alpha 1}, k_{\alpha 2}, k_{\beta 1}, k_{\beta 2} \in \mathbb{R}^+$ such that, for all $\theta \in \mathbb{R}$: i) $h(\theta) \in [h_m, h_M]$; ii) $\left| \frac{\partial h(\theta)}{\partial \theta} \right| \leq k_h$; $|\alpha(\theta)| \leq k_{\alpha 1}$; $\left| \frac{\partial \alpha(\theta)}{\partial \theta} \right| \leq k_{\alpha 2}$; $|\beta(\theta)| \leq k_{\beta 1}$; $\left| \frac{\partial \beta(\theta)}{\partial \theta} \right| \leq k_{\beta 2}$.

3. SEMI-GLOBAL SPEED TRACKING

In this section we preliminarily provide a semi-global solution to the rotor speed tracking problem. Let $\dot{\theta}^*(t) \doteq \omega_r(t)$ be an assigned speed reference signal and denote by $\eta = \omega - \omega_r$ the corresponding speed tracking error. Since, according to the motor torque expression in (1), a non-zero i_d only contributes to torque ripples, it is desirable to set $i_d = 0$ while choosing i_q to produce the desired torque reference (see for instance [8]). System (1) becomes

$$\begin{aligned} \dot{\theta} &= \omega_r + \eta & (2) \\ \dot{\eta} &= h(\theta)^{-1}(-\alpha(\theta) - \beta(\theta)(\omega_r + \eta) - h(\theta)\dot{\omega}_r + h(\theta)i_q) \\ &= h(\theta)^{-1}([\alpha(\theta), \beta(\theta), h(\theta)][-1, -\eta - \omega_r, -\dot{\omega}_r]^T + i_q) \end{aligned}$$

which can be compactly rewritten (with an unambiguous notation) in the more general form

$$\begin{aligned} \dot{\theta} &= \omega_r + \eta \\ \dot{\eta} &= g(\theta) (\delta^*(\theta)^T f(\theta, \eta, t) + i_q), \end{aligned} \quad (3)$$

where $\delta^* : \mathbb{R} \rightarrow \mathbb{R}^m$ and $g : \mathbb{R} \rightarrow \mathbb{R}$ are uncertain T -periodic functions of class \mathcal{C}^2 , whereas $f : \mathbb{R}^3 \rightarrow \mathbb{R}^m$ is a known function of its arguments. Namely, system (2) takes on form (3) by setting $\delta^*(\theta) = [\alpha(\theta), \beta(\theta), h(\theta)]^T$, $g(\theta) = h(\theta)^{-1}$, $f(\cdot, \eta, t) = [-1, -\eta - \omega_r(t), -\dot{\omega}_r(t)]^T$. Note that, in the specific case of (2), function f does not depend on θ . However, our problem formulation and design strategy will even allow for a more generally θ -dependent $f(\cdot)$. The aim of this section is to design a feedback learning controller for the input i_q , such that the rotor speed tracking error η asymptotically converges to 0, despite the fact that δ and g are uncertain. On the basis of A.1)-A.3) we formalize the assumptions for this section.

Assumption 3.1. There exist known positive constants g^- , δ^+ , ω^- , ω^+ and a known function $f^+ : \mathbb{R}^+ \rightarrow \mathbb{R}^+$ such that: $g(\theta) > g^-$; $\|\delta^*(\theta)\| \leq \delta^+ \forall \theta \in \mathbb{R}$; $\omega^- \leq \omega_r(t) \leq \omega^+ \forall t \in \mathbb{R}$; $\|f(\theta, \eta, t)\| \leq f^+(|\eta|) \forall \theta, \eta, t \in \mathbb{R}$.

Namely, the above assumption requires the term $g(\cdot)$ to be bounded from below by a positive constant: it guarantees that system (3) has a well defined relative degree of 2 with respect to output θ . Moreover, the uncertain function $\delta^*(\cdot)$ needs to be bounded in norm by a known value δ^+ , which can be computed on the basis of the $h(\cdot)$, $\alpha(\cdot)$, $\beta(\cdot)$ - expressions and of assumptions A.1)-A.3). Further, the reference velocity $\omega_r(t)$ needs to be bounded from below and from above by positive constants. Finally, the known function $f(\cdot)$ must be bounded by a positive

function that depends only on the absolute value of η . Note that this last assumption, in the specific case of (2), is satisfied if function $|\dot{\omega}_r|$, in addition to $|\omega_r|$, is bounded. As we shall see, the knowledge of the bounds g^- , ω^- , δ^+ and f^+ will be involved in the choice of control gain k characterizing the proportional action of the control on the rotor speed tracking error. The proposed input law is a P-type repetitive space-learning control that reads³:

$$\begin{aligned} i_q &= -k\eta - \delta(\theta)^T f(\theta, \eta, t) \\ \delta(\theta) &= \text{sat}_{\delta^+}(\delta(\theta - T)) + \mu\eta f(\theta, \eta, \cdot)q(\dot{\theta}, \eta), \end{aligned} \quad (4)$$

where $k, \mu \in \mathbb{R}$ are gain terms, $\bar{\eta} < \omega^-$ is a positive constant, $\delta : \mathbb{R} \rightarrow \mathbb{R}^m$ is a learning estimation term, while $q : \mathbb{R}^2 \rightarrow \mathbb{R}$ is defined as $q(\dot{\theta}, \eta) = \dot{\theta}^{-1}$, if $|\eta| < \bar{\eta}$ and $q(\dot{\theta}, \eta) = 0$ otherwise. Function $\text{sat}_{\delta^+} : \mathbb{R}^m \rightarrow \mathbb{R}^m$ is the component-wise saturation function, that is if $(y_1, y_2, \dots, y_m) = \text{sat}_{\delta^+}((x_1, x_2, \dots, x_m))$, then $y_i = x_i$ if $|x_i| < \delta^+$ and $y_i = \delta^+ \text{sgn}(x_i)$ otherwise. Note that the closed-loop system (3)+(4) is a delay differential equation. Its initial condition is given by $\theta(0)$, $\eta(0)$ together with $\delta|_{[-T, 0]}$ (i.e. the restriction of δ in the interval $[-T, 0]$). The following theorem constitutes the main result of this section.

Theorem 3.1. If assumption 3.1 is satisfied, then for any initial condition and for each positive real constant $\bar{\eta} < \omega^-$, there exist known real values for the gains k , μ such that the solution of system (3) with controller (4) satisfies the following properties: a) for any initial condition $\theta(0)$, $\eta(0)$, $\delta|_{[-T, 0]}$, there exists \bar{t} such that $|\eta(t)| \leq \bar{\eta}$, $\forall t \geq \bar{t}$; b) $\dot{\theta}(t)$ asymptotically converges to $\omega_r(t)$, that is $\lim_{t \rightarrow \infty} \eta(t) = 0$.

Proof. Since $g(\cdot)$ is a periodic \mathcal{C}^2 -function of its argument and assumption 3.1 holds, there exist constants g^+ , g_d such that

$$|g(\theta)| \leq g^+, |(g^{-1})'(\theta)| \leq g_d, \forall \theta \in \mathbb{R}.$$

If we set $W(\eta) = \frac{1}{2}\eta^2$ and define the estimation error $\tilde{\delta} = \delta - \delta^*$, then the derivative of W along the solutions of (3)+(4) satisfies

$$\dot{W}(\theta, \eta) = \eta g(\theta)(-\tilde{\delta}(\theta)^T f(\theta, \eta, \cdot) - k\eta) \leq W^+(\eta),$$

with

$$W^+(\eta) = \begin{cases} A_W(\eta) & \text{if } |\eta| > \bar{\eta} \\ B_W(\eta) & \text{if } |\eta| \leq \bar{\eta}, \end{cases}$$

and

$$\begin{aligned} A_W(\eta) &= -kg^-\eta^2 + 2g^+\delta^+f^+\eta \\ B_W(\eta) &= -kg^-\eta^2 + g^+(2\delta^+ + \mu|\eta|(\omega^- - \bar{\eta})^{-1})f^+|\eta|. \end{aligned}$$

In the previous inequality, we have used: i) the definition of δ in (4); ii) assumption 3.1; iii) $\|\delta(\theta)\| \leq \delta^+ + \mu\eta f^+|q(t)|$ (see the second equation in (4)); $|q(t)| \leq (\omega^- - \bar{\eta})^{-1}$ for

³ No clear approach is available, when the entire learning update rule is saturated, to determine the stability of the closed loop error system through a Lyapunov-like based approach (see [12]).

$|\eta| \leq \bar{\eta}$. Choose k sufficiently large such that $B_W(\bar{\eta}) \leq 0$, namely set

$$k > \frac{g^+(2\delta^+ + \mu\bar{\eta}(\omega^- - \bar{\eta})^{-1})f^+\bar{\eta}}{g^-\bar{\eta}^2}$$

so that $W^+(\eta) < 0$ for any $\eta \geq \bar{\eta}$ and property a) holds. Note that, for any $t \geq \bar{t}$, $\eta(t) \leq \bar{\eta}$; it implies $\dot{\theta}(t) > 0$ for any $t \geq \bar{t}$ so that, in the control law (4) [which is therefore well-defined], $q(t) = \dot{\theta}^{-1}(t)$, for any $t \geq \bar{t}$. Define the functional on $\mathbb{R}^2 \times L_{2,loc}(\mathbb{R})^m$

$$V(\theta, \eta, \Delta) = \frac{1}{2} \left(g^{-1}(\theta)\eta^2 + \mu^{-1} \int_{\theta-T}^{\theta} \|\Delta(\theta)\|^2 \right),$$

where $\Delta(\theta) = \text{sat}_{\delta^+}(\delta(\theta)) - \delta^*(\theta)$. Note that the quantity

$$I_t = \frac{d}{dt} \int_{\theta(t)-T}^{\theta(t)} \|\Delta(y)\|^2 dy$$

satisfies (here $f(\cdot)$ denotes $f(\theta(t), \eta(t), t)$)

$$\begin{aligned} I_t &= \dot{\theta}(t) \left(\|\text{sat}_{\delta^+}(\delta(\theta(t))) - \delta^*(\theta(t))\|^2 \right. \\ &\quad \left. - \|\text{sat}_{\delta^+}(\delta(\theta(t) - T)) - \delta^*(\theta(t))\|^2 \right) \\ &\leq \dot{\theta}(t) \left(\|\delta(\theta(t)) - \delta^*(\theta(t))\|^2 - \|\mu\eta(t)f(\cdot)\dot{\theta}(t)^{-1} \right. \\ &\quad \left. + \delta(\theta(t)) - \delta^*(\theta(t))\|^2 \right) \\ &\leq \mu\eta(t)f(\cdot)^T (2\tilde{\delta}(\theta(t)) - \mu\eta(t)f(\cdot)\dot{\theta}(t)^{-1}) \\ &\leq 2\mu\eta(t)\tilde{\delta}(\theta(t))^T f(\cdot) \end{aligned}$$

according to the fact that $\|\text{sat}_{\delta^+}(\delta(\theta(t)) - \delta^*(\theta(t)))\|^2 \leq \|\delta(\theta(t)) - \delta^*(\theta(t))\|^2$ as well as to the property

$$\|a\|^2 - \|b\|^2 = a^T a - b^T b = (a+b)^T (a-b), \quad \forall a, b \in \mathbb{R}^m.$$

The derivative of V along the solutions of (3)+(4) thus satisfies for any $t \geq \bar{t}$:

$$\dot{V}(\theta, \eta, \tilde{\delta}) \leq -k\eta^2 + \frac{1}{2}\dot{g}^{-1}(\theta)\dot{\theta}\eta^2. \quad (5)$$

Since $\dot{\theta} \leq \omega^+ + |\eta| \leq \omega^+ + \bar{\eta}$ for any $t \geq \bar{t}$, it follows that

$$\dot{V}(\theta, \eta, \tilde{\delta}) \leq -\left(k - \frac{g_d}{2}(\bar{\eta} + \omega^+)\right)\eta^2.$$

If necessary, the value of the gain k is increased such that $k > g_d(\bar{\eta} + \omega^+)/2$ so that V is definite negative for $|\eta| \leq \bar{\eta}$. Let $Z(t) = V(\theta(t), \eta(t), \Delta(t))$, where θ, η, Δ are evaluated along the solution of (3)+(4). Barbalat's Lemma finally applies so that property b) holds.

4. LOCAL POSITION TRACKING

In this section we slightly modify the previously used arguments in order to achieve a local solution to the rotor position tracking problem. As in the previous section and in contrast to [7], we will use to our advantage the aforementioned θ -periodicity of the uncertain functions $\alpha(\theta), \beta(\theta), h(\theta)$. However, in contrast with the previous

section as well as to [22], [23] (and even [11]), the state-dependent (namely, θ -dependent) periodicity will be here explicitly expressed in terms of the corresponding state reference (namely θ^*), which is always guaranteed to be strictly time-increasing. This strictly time-increasing nature will be crucial in presenting - in this section - an alternative, equivalent stability proof which involves an explicit change of time-scale and avoids the computation of \bar{t} in the definition of the switching function $q(\cdot)$ in (3). In the following we will use the symbol g to denote, as in [7], a new quantity since no ambiguity occurs. Furthermore we will adopt the same symbols as in [7] to denote the bounds on the rotor speed reference. Let $\theta^*(t)$ be the smooth, strictly time-increasing, non-time-periodic reference signal for the rotor position whose time derivative $\dot{\theta}^*(t)$ is assumed to belong to the following class: A.4) $\dot{\theta}^*(t)$ for any t satisfies $\dot{\theta}^*(t) \geq c_\omega > 0$ with c_ω being a positive real and $|\dot{\theta}^*(t)| \leq c_{\theta 1}$, $|\ddot{\theta}^*(t)| \leq c_{\theta 2}$, with $c_{\theta 1}, c_{\theta 2}$ being known positive reals. Let $\theta^*(t)$ be written as the strictly increasing integral function $\theta^*(t) = \theta^*(0) + \int_0^t \dot{\theta}^*(\tau) d\tau$ and let $\tilde{\theta} = \theta - \theta^*$ be the corresponding rotor position tracking error. Since $\theta^*(t) \doteq \psi(t)$ is a strictly increasing time function on \mathbb{R} , its inverse function $\psi^{-1}(\theta^*)$ exists. It is of class \mathcal{C}^1 and strictly increasing on \mathbb{R} . In the reminder of this section we consider the generic time function $x(t)$ and define the corresponding θ^* -function

$$x_s(\theta^*) = x(\psi^{-1}(\theta^*))$$

with its θ^* -derivative $\frac{dx_s(\theta^*)}{d\theta^*}$ denoted by $x'_s(\theta^*)$ satisfying

$$x'_s(\theta^*) = \frac{\dot{x}(\psi^{-1}(\theta^*))}{\dot{\theta}^*(\psi^{-1}(\theta^*))}.$$

The control input i_q in (3) is modified as follows (k_θ, k_ω and k_v are positive control parameters, $v(\cdot)$ is the robustifying term as in [7], $\mu_\alpha, \mu_\beta, \mu_h$ are the learning gains, $k_{\alpha 1}, k_{\beta 1}, h_M$ - similarly to δ^+ for δ^* - are the known bounds for $|\alpha(\theta^*)|, |\beta(\theta^*)|, |h(\theta^*)|$)⁴

$$\begin{aligned} i_q(t) &= -k_\omega \tilde{\omega}(t) - k_v \tilde{\theta}_{tq}(t) - v(\omega(t))\tilde{\omega}(t) + \hat{i}_{qr}(t) \\ \tilde{\omega} &= \omega + k_\theta \tilde{\theta}_{tq} - \dot{\theta}^* \\ \tilde{\theta}_{tq} &= -\text{atan2} \left(\frac{\sin(\theta^*)\cos(\theta) - \sin(\theta)\cos(\theta^*)}{\cos(\theta^*)\cos(\theta) + \sin(\theta)\sin(\theta^*)} \right) \\ \hat{i}_{qrs}(\theta^*) &= \hat{\alpha}(\theta^*) + \hat{\beta}(\theta^*)\dot{\theta}_s^*(\theta^*) + \hat{h}(\theta^*)\ddot{\theta}_s^*(\theta^*) \\ \hat{\alpha}(\theta^*) &= \text{sat}_{k_{\alpha 1}}(\hat{\alpha}(\theta^* - T)) - \frac{\mu_\alpha}{\dot{\theta}_s^*(\theta^*)}\tilde{\omega}_s(\theta^*) \\ \hat{\beta}(\theta^*) &= \text{sat}_{k_{\beta 1}}(\hat{\beta}(\theta^* - T)) - \mu_\beta \tilde{\omega}_s(\theta^*) \\ \hat{h}(\theta^*) &= \text{sat}_{h_M}(\hat{h}(\theta^* - T)) - \frac{\mu_h \ddot{\theta}_s^*(\theta^*)}{\dot{\theta}_s^*(\theta^*)}\tilde{\omega}_s(\theta^*). \end{aligned} \quad (6)$$

Here we have used back-stepping techniques to add to the design of the previous section, a rotor position tracking control loop⁵, in which the error $\tilde{\theta}_{tq} = -\text{atan2}(\text{tg}(-\tilde{\theta}))$

⁴ As in the previous section, no continuity correction functions (see details in [25]) are here used for the sake of simplicity and clarity.

⁵ The choice of $\tilde{\omega}$ in (6) is motivated as follows. The rotor position tracking error dynamics accordingly read $\dot{\tilde{\theta}} = \omega - \dot{\theta}^* = -k_\theta \tilde{\theta}_{tq} + \tilde{\omega}$; simultaneously guaranteeing $\lim_{t \rightarrow +\infty} \tilde{\theta}(t) = 0$ and $\lim_{t \rightarrow +\infty} \tilde{\omega}(t) =$

coincides with $\tilde{\theta}$ for sufficiently small $\tilde{\theta} \in (-\pi/2, \pi/2)$. In contrast to [8], the advantage of using, in the feedback action, $\tilde{\theta}_{tg}$ in place of $\tilde{\theta}$ relies on the necessity of using the $\theta_{|2\pi}$ -measurements which are typically provided by an encoder while avoiding the computation of $\theta_{|2\pi} - \theta^*$, which may lead to time-discontinuities when θ or θ^* go out of the set $[0, 2\pi)$. The price to be paid, as stated by the following theorem, is, however, the local nature of the resulting control (which can be removed when $\tilde{\theta}$ replaces $\tilde{\theta}_{tg}$).

Theorem 4.1. Consider the current-fed permanent magnet motor (1) under assumptions A.1)-A.3) in closed loop with the robust repetitive learning control algorithm (6). Let $\theta^*(t)$ be the rotor position reference signal whose time derivative belongs to the class A.4). Then, for sufficiently small initial conditions $\tilde{\theta}(0)$, $\tilde{\omega}(0)$ and sufficiently large learning gains μ_α , μ_β , μ_h , the following properties hold: i) the error variables $(\tilde{\theta}(t), \tilde{\omega}(t))$ and the control inputs $(i_d(t), i_q(t))$ are bounded on $[0, +\infty)$; ii) asymptotic rotor position/speed tracking $\lim_{t \rightarrow \infty} [\tilde{\theta}^2(t) + \tilde{\omega}^2(t)] = 0$ is achieved.

Proof. If we change the time-scale and rewrite the $(\tilde{\theta}, \tilde{\omega})$ -error equations with respect to the new time-variable θ^* , then we obtain for sufficiently small $\tilde{\theta} \in (-\pi/2, \pi/2)$ the dynamic equations

$$\begin{aligned}\tilde{\theta}'_s &= \frac{1}{\tilde{\theta}^*_s} \left[-k_\theta \tilde{\theta}_s + \tilde{\omega}_s \right] \\ h(\theta_s) \tilde{\omega}'_s &= \frac{1}{\tilde{\theta}^*_s} \left[-k_\omega \tilde{\omega}_s - k_v \tilde{\theta}_s - g(\tilde{\theta}_s, \tilde{\omega}_s, \omega_s) - v(\omega_s) \tilde{\omega}_s \right. \\ &\quad \left. - \alpha - \beta \dot{\theta}^*_s - h \ddot{\theta}^*_s + \hat{i}_{qrs} \right]\end{aligned}$$

where $g(\cdot)$ is defined⁶ as in [7], while \hat{i}_{qrs} is the estimate of the input reference $i_{qrs} = \alpha + \beta \dot{\theta}^*_s + h \ddot{\theta}^*_s$. Properties i) and ii) thus follow on considering the quadratic-integral Lyapunov-like function (see function V in the previous section as well as [12] and [25] for the related ideas)

0 implies the desired convergence properties: $\lim_{t \rightarrow +\infty} [\theta(t) - \theta^*(t)] = 0$, $\lim_{t \rightarrow +\infty} [\omega(t) - \dot{\theta}^*(t)] = 0$.

⁶ In particular $g(\cdot)$ reads

$$\begin{aligned}g(\tilde{\theta}, \tilde{\omega}, \omega) &= -h(\theta) k_\theta \tilde{\omega} + h(\theta) k_\theta^2 \tilde{\theta} + \alpha(\theta) - \alpha(\theta^*) \\ &\quad + \beta(\theta^*)(\tilde{\omega} - k_\theta \tilde{\theta}) + [\beta(\theta) - \beta(\theta^*)] \omega + [h(\theta) - h(\theta^*)] \ddot{\theta}^*\end{aligned}$$

and satisfies, according to A.1)-A.4),

$$\begin{aligned}|g(\tilde{\theta}, \tilde{\omega}, \omega)| &\leq [k_h c_{\theta 2} + k_{\beta 1} k_\theta + k_{\beta 2} |\omega| + k_{\alpha 2} + h_M k_\theta^2] |\tilde{\theta}| \\ &\quad + [k_{\beta 1} + h_M k_\theta] |\tilde{\omega}| \doteq s_1(\omega) |\tilde{\theta}| + g_2 |\tilde{\omega}|,\end{aligned}$$

with $s_1^2(\omega) \leq g_1(\omega)$ and $g_1(\cdot)$ and g_2 being explicitly defined as

$$\begin{aligned}g_1(\omega) &= 5h_M^2 k_\theta^4 + 5k_h^2 c_{\theta 2}^2 + 5k_{\beta 1}^2 k_\theta^2 + 5k_{\beta 2}^2 \omega^2 + 5k_{\alpha 2}^2 \\ g_2 &= k_{\beta 1} + h_M k_\theta\end{aligned}$$

in the expression for v in [7] as (k and \bar{k}_ω are positive control parameters)

$$v(\omega) = \frac{g_1(\omega)}{2k_\theta k_v} + g_2 + \frac{k}{4} + \frac{\bar{k}_\omega}{4} + \frac{k_h^2 \omega^2}{4\bar{k}_\omega}.$$

$$\begin{aligned}V_s(\theta^*) &= \frac{1}{2} \left[k_v \tilde{\theta}_s^2(\theta^*) + h(\theta_s(\theta^*)) \tilde{\omega}_s^2(\theta^*) \right] \\ &\quad + \sum_{q=\alpha, \beta} \frac{1}{2\mu_q} \int_{\theta^*-T}^{\theta^*} [q(\tau) - \text{sat}_{k_{q1}}(\hat{q}(\tau))]^2 d\tau \\ &\quad + \frac{1}{2\mu_h} \int_{\theta^*-T}^{\theta^*} [h(\tau) - \text{sat}_{h_M}(\hat{h}(\tau))]^2 d\tau\end{aligned}$$

along with its θ^* -derivative which satisfies along the trajectories of the closed loop system - expressed in the new time variable θ^* - the inequality (complete the squares and use the definition of the learning estimation schemes in (6))

$$V'_s(\theta^*) \leq -\frac{1}{\tilde{\theta}^*_s(\theta^*)} \left[\frac{k_v k_\theta}{2} \tilde{\theta}_s^2(\theta^*) + \left(k_\omega + \frac{k}{4} \right) \tilde{\omega}_s^2(\theta^*) \right]. \quad (7)$$

Since $\tilde{\theta}_s(\theta^*)$ and $\tilde{\omega}_s(\theta^*)$ are bounded on $[\theta^*(0), +\infty)$, $\hat{i}_{qrs}(\theta^*)$ is bounded on $[\theta^*(0), +\infty)$ and therefore $i_{qs}(\theta^*)$ is bounded on $[\theta^*(0), +\infty)$. Since $\tilde{\theta}'_s(\theta^*)$ and $\tilde{\omega}'_s(\theta^*)$ are bounded on $[\theta^*(0), +\infty)$, $\tilde{\theta}_s^2(\theta^*)$ and $\tilde{\omega}_s^2(\theta^*)$ are uniformly continuous on $[\theta^*(0), +\infty)$ and therefore, by Barbalat's Lemma, we can write

$$\lim_{\theta^* \rightarrow \infty} [\tilde{\theta}_s^2(\theta^*) + \tilde{\omega}_s^2(\theta^*)] = 0,$$

which implies⁷

$$\lim_{t \rightarrow \infty} [\tilde{\theta}^2(t) + \tilde{\omega}^2(t)] = 0.$$

It is clear that the above result holds for sufficiently small initial conditions $\tilde{\theta}(0)$, $\tilde{\omega}(0)$ and sufficiently large learning gains μ_α , μ_β , μ_h guaranteeing for any t - through $V_s(\theta^*) \leq V_s(\theta^*(0))$ - sufficiently small $\tilde{\theta}(t)$ in the open set $(-\pi/2, \pi/2)$.

The following comments are in order.

- The above control input i_q in (6) incorporates the PD position control (with gains k_p and k_d):

$$-k_\omega \tilde{\omega}(t) - k_v \tilde{\theta}(t) = -(k_v + k_\omega k_\theta) \tilde{\theta}(t) - k_\omega \dot{\tilde{\theta}}(t)$$

along with the plug-in signal $\hat{i}_{qr}(t)$ which generalizes the integral action $-k_i \int_0^t \tilde{\theta}(\tau) d\tau$, which is typically used to compensate the effects of (time-) constant disturbances.

- When $\dot{\theta}^*$ is constant, the whole disturbance function $q(\cdot)$ reduces to $\alpha_e(\cdot) = \alpha(\cdot) + \dot{\theta}^* \beta(\cdot)$ which is θ^* -periodic with only one space-learning estimation scheme being sufficient to guarantee the asymptotic rotor position tracking. In this case, $\theta^*(t) = \theta^*(0) + \dot{\theta}^* t$ defines a different time scale involving the stretch of the time-variable t : the resulting space-learning control is equivalent to a time-learning one since $\alpha_e(\theta^*(t))$ is also time-periodic.

⁷ Through arguments similar to those previously used, we can establish that if the resulting $\hat{i}_{qrs}(\theta^*)$ is an uniformly continuous function on $[\theta^*(0), +\infty)$ (and this necessarily implies $\tilde{\omega}(0) = 0$ in our case), then $\lim_{t \rightarrow \infty} [i_{qr}(t) - \hat{i}_{qr}(t)] = 0$.

- Permanent magnet synchronous motors with cogging torque exhibit constant β and h , so that the last two repetitive learning estimation schemes in (6) can be either implemented with any sufficiently small T or simply replaced by integral actions (with only the estimation law for $\hat{\beta}(\cdot)$ surviving when $\dot{\theta}^*$ is constant).
- If the adaptive learning approach of [24] is applied in the new time coordinate, then results similar to the ones presented in [8] can be obtained with residual steady-state tracking errors however appearing due to truncation errors in the corresponding Fourier series expansions.
- The above repetitive learning approach (in (4) and (6)) apparently uses, to generate the signal to be exerted in each trial, the input recorded during the previous trial in conjunction with the actual tracking error being weighted through a learning gain and a gain function. The presence of the saturation as well as of filtering actions as in [7] may be useful to avoid, in practice, long term instability problems owing to noise accumulation over periods ([21]).

5. A TYPICAL ELECTRIC DRIVE SIMULATION

A simplified discrete-time version (with sampling time $T_s = 100 \mu\text{s}$) of the controller (6) of Section 4 (with i_d^* and i_q^* in place of i_d and i_q) in conjunction with a PI (proportional-integral) current loop (with SI units-proportional and integral gains $K_{pI} = 1$ and $K_{iI} = 500$, respectively) relying on the stator current tracking errors i_d and $(i_q - i_q^*)$ is derived (see Figure 1). As usual in standard electric drives, a saturation for the i_q -reference is inserted, with values respectively equal to 15 A and -15 A. The angle and speed control loops are realized, as in most industrial electric drives, using the electrical angle and speed, obtained by multiplying the mechanical quantities by the number N_r of rotor teeth. The controller of Figure 1 is simulated with reference to the voltage-fed permanent magnet stepper motor described in [17]: stator current dynamics, which have been neglected at the design stage, are taken into account. The full-order motor model reads $[(u_d, u_q)$ are the stator voltage vector (d, q) components, R and L_0 are the stator windings resistance and the self inductance, respectively]:

$$\begin{aligned} \frac{d\theta(t)}{dt} &= \omega(t) \\ \frac{d\omega(t)}{dt} &= -\frac{D}{J}\omega(t) + \frac{i_f N_r}{J} \sum_{j=2}^n j L_{mj} \sin[(1-j)N_r\theta(t)] i_d(t) \\ &\quad - \frac{N_r i_f^2}{2J} \sum_{j=4}^n j L_{fj} \sin[jN_r\theta(t)] - \frac{T_L(\theta(t))}{J} \\ &\quad + \frac{i_f N_r}{J} \sum_{j=1}^n j L_{mj} \cos[(1-j)N_r\theta(t)] i_q(t) \\ \frac{di_d(t)}{dt} &= -\frac{R}{L_0} i_d(t) + N_r i_q(t) \omega(t) + \frac{1}{L_0} u_d(t) \\ &\quad + \frac{i_f N_r}{L_0} \sum_{j=2}^n j L_{mj} \sin[(j-1)N_r\theta(t)] \omega(t) \\ \frac{di_q(t)}{dt} &= -\frac{R}{L_0} i_q(t) - N_r i_d(t) \omega(t) + \frac{1}{L_0} u_q(t) \end{aligned}$$

$$-\frac{i_f N_r}{L_0} \sum_{j=1}^n j L_{mj} \cos[(j-1)N_r\theta(t)] \omega(t).$$

The load torque is $T_L(\theta) = N_T \sin(\theta)$ while the motor parameters are: $J = 0.0733 \text{ kgm}^2$, $m = 4$, $L_{m1} = 5 \text{ mH}$, $L_{m2} = 0.5 \text{ mH}$, $L_{m3} = 0.166 \text{ mH}$, $L_{m4} = 0.0625 \text{ mH}$, $L_{f4} = 1.766 \text{ mH}$, $N_r = 50$, $i_f = 1 \text{ A}$, $D = 0.002 \text{ kgm}^2/\text{s}$, $N_T = 1.7201 \text{ kgm}^2/\text{s}^2$, $R = 1 \text{ Ohm}$, $L_0 = 0.7 \text{ mH}$. In the considered robotic application, the load torque $T_L = N_T \sin(\theta)$ models the position-dependent single link robotic load represented by a metal bar link attached to the rotor shaft and a brass ball attached to the free end and required to track the aforementioned rotor position/speed references. In order to validate the space-learning strategy, the frequency modulation speed reference signal $N_r \dot{\theta}^*(t) = 15 + 5 * \sin(2\pi t + \sin(\pi t))$ is chosen (see Figure 2). The electrical angle reference signal is the integral of $N_r \dot{\theta}^*(t)$ with zero initial condition. The time function $P_t(t)$, which satisfies $\theta^*(t - P_t(t)) = \theta^*(t) - T$ (see [22], [23] for an analogous interpretation), is computed, in the considered simulation, through the differential equation (with the stabilizing positive gain $k_{pp} = 10$ and initial condition $P_t(0) = 3 \text{ s}$)

$$\dot{P}_t(t) = 1 - \frac{\dot{\theta}^*(t) + k_{pp}(\theta^*(t) - T - \theta^*(t - P_t(t)))}{\dot{\theta}^*(t - P_t(t))}$$

which is obtained from the relationship $\frac{d}{dt}[\theta^*(t - P_t(t)) - \theta^*(t) + T] = -k_{pp}[\theta^*(t - P_t(t)) - \theta^*(t) + T]$ being satisfied by a correctly initialized $P_t(t)$. The gains for the classical closed loop position control are (in SI units): $k_\theta=5$ (k in the block diagram), $k_\omega=5$ ($k_{p\omega}$ in the block diagram), $k_{I\omega}=50$ (integral action gain). It is important to put in evidence that these constants are tuned in order to obtain the best performance for the traditional closed loop position control. The space-learning compensation term $\hat{i}_{qr}(t)$ is applied to the system at the time instant $t = 5 \text{ s}$. From this time instant the gains μ_α , μ_β , μ_h are increased, starting from the null value to their final values 250, 0.1 and 0.1, respectively, with a ramp of 1 s. At the same time, $t = 5 \text{ s}$, the integral gain $k_{I\omega}$ of the angle/speed PI regulator is gradually annihilated with the same 1 s-ramp. After the time instant $t = 5 \text{ s}$, the role played by the integral action of the traditional closed loop control is played by the space-learning compensation action. The advantageous effect of such a space-learning compensation action on the electric rotor speed and angle tracking errors is apparently highlighted by Figure 3: after short transients - when the time crosses the value $t = 5 \text{ s}$ -, the peak-to-peak speed tracking error passes from the value 0.72 rad/s to the smaller one 0.081 rad/s, while the peak-to-peak angle tracking error passes from the value 0.03 rad to the smaller one 0.006 rad. Figure 4 shows the time histories of the uncertain input reference signal $i_{qr}(t)$ (not periodic in time) with its estimate $\hat{i}_{qr}(t)$. The time history of the time-function $P_t(t)$ is also reported in Figure 4. The persisting non-zero value for the angle tracking error $\tilde{\theta}(t)$ (and consequently for the tracking error $\tilde{\omega}(t) = \omega(t) - \dot{\theta}^*(t) + k_\theta \tilde{\theta}(t)$) for $t \in [5, 7] \text{ s}$ is due to the transient behaviour of the $i_{qr}(t)$ -input-reference recovering action by the $i_q(t)$ -current, as shown by the related Figure 5. In summary, satisfactory input reference estimation

(even in the presence of digital implementation, numerical integration errors and additional current dynamics) and rotor speed/angle tracking are achieved after $t = 5$ s, while stator currents in the rotating (d, q) reference frame (see Figure 6) are within physical limits and satisfactorily track their reference signals $i_d^*(t)$ and $i_q^*(t)$.

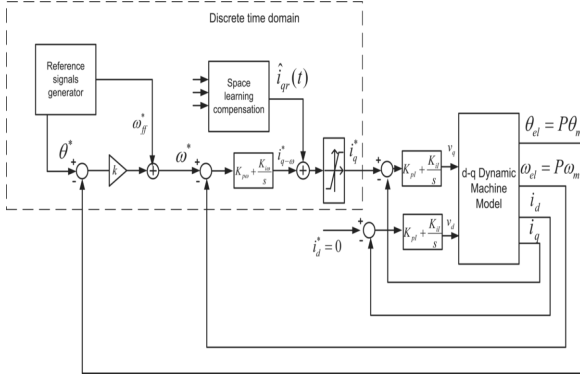

Fig. 1. Block diagram for the realistic simulation (P denotes N_r , ω_{*f} denotes $\dot{\theta}^*$, θ_m denotes θ , ω_m denotes ω).

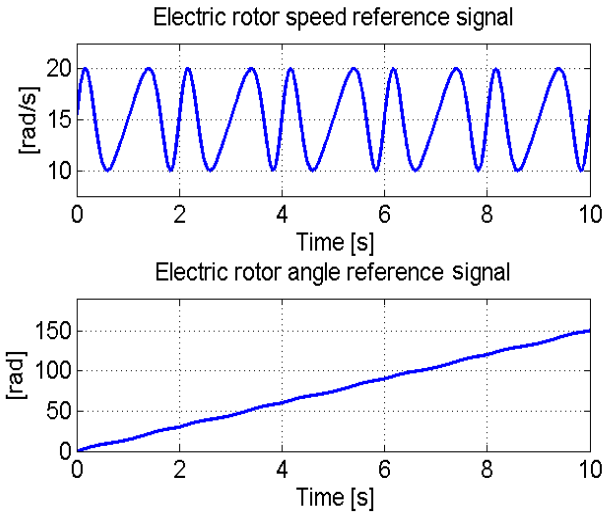

Fig. 2. Electric rotor speed and angle reference signals $N_r \dot{\theta}^*(t)$ and $N_r \theta^*(t)$.

6. CONCLUSIONS

Space-learning controls are designed for current-fed uncertain permanent magnet step motors (1) with non-sinusoidal flux distribution and uncertain position-dependent load torque. The corresponding stability analyses show that semi-global/local asymptotic rotor speed/position tracking is achieved by only relying on the position-periodic structure of the uncertain position-functions characterizing the motor dynamics. Realistic simulation results finally illustrate the effectiveness of the presented approach in a typical electric drive control scenario in which stator

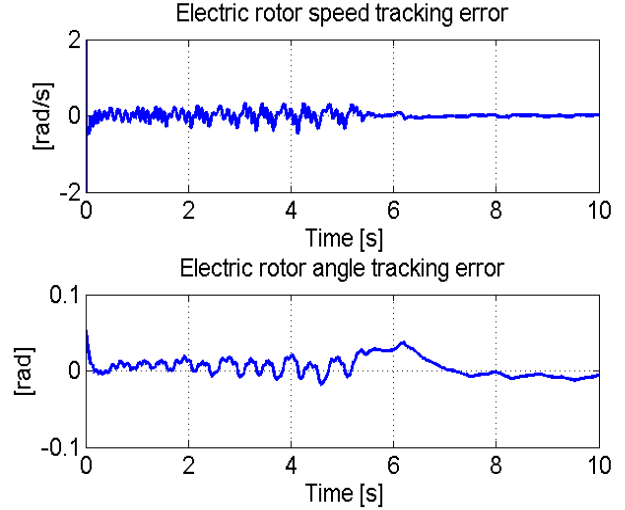

Fig. 3. Electric rotor speed and angle tracking errors $N_r(\omega(t) - \dot{\theta}^*(t))$ and $N_r(\theta(t) - \theta^*(t))$.

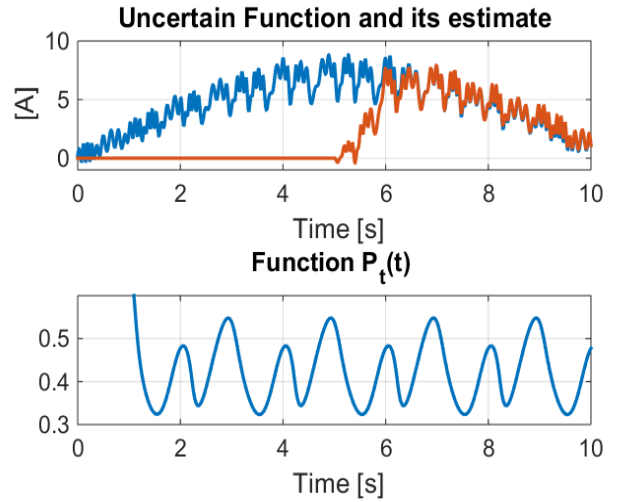

Fig. 4. Function $i_{qr}(t)$ and its estimate $\hat{i}_{qr}(t)$; "time-varying" period $P_t(t)$.

current dynamics - neglected at the design stage - are explicitly taken into account.

REFERENCES

- [1] H.-S. Ahn and Y.-Q. Chen. State-dependent friction force compensation using periodic adaptive learning control. *Mechatronics*, 19:896-904, 2009.
- [2] H.-S. Ahn, Y.Q. Chen, and K.L. Moore. Iterative learning control: brief survey and categorization. *IEEE Transactions on Systems, Man, and Cybernetics - Part C: Applications and Reviews*, 37:1099-1121, 2007.
- [3] H.-S. Ahn, Y.Q. Chen, and H. Dou. State-periodic adaptive compensation of cogging and coulomb friction in permanent-magnet linear motors. *IEEE Transactions on Magnetics*, 41: 90-98, 2005.
- [4] F. Betin, D. Pinchon, and G.-A. Capolino. Fuzzy logic applied to speed control of a stepping motor drive. *IEEE Transactions on Industrial Electronics*, 47:610-622, 2000.
- [5] S. Bifaretti, V. Iacovone, A. Rocchi, P. Tomei, and C.M. Verrelli. Global learning position controls for permanent magnet step motors. *IEEE Transactions on Industrial Electronics*, 58: 4654-4663, 2011.

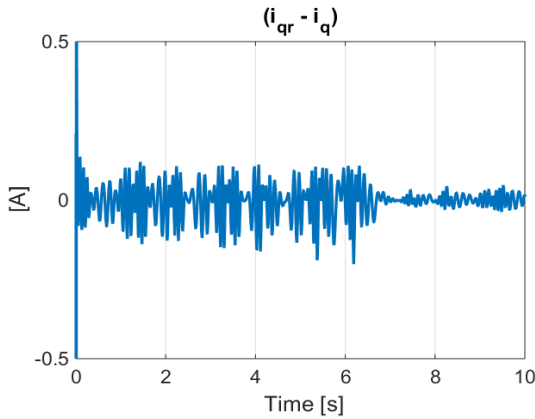

Fig. 5. Stator current $i_q(t)$ and function $i_{qr}(t)$.

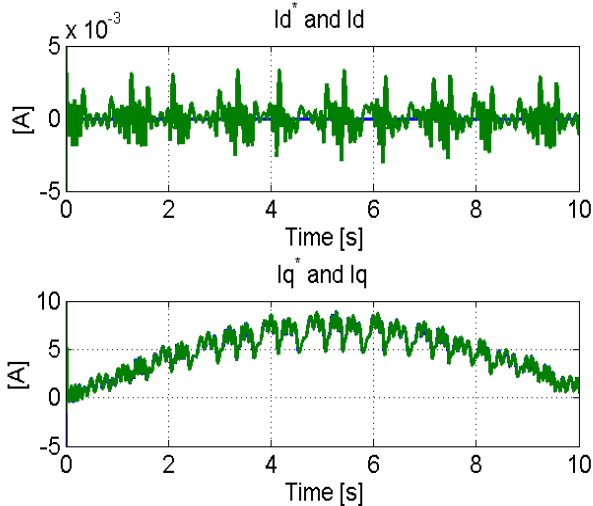

Fig. 6. Stator current vector (d, q) components and their references.

- [6] S. Bifaretti, V. Salis, P. Tomei, and C.M. Verrelli. Repetitive learning position control for full order model- permanent magnet step motors. *Automatica*, 63:274–286, 2016.
- [7] S. Bifaretti, P. Tomei, and C.M. Verrelli. A global robust iterative learning position control for current-fed permanent magnet step motors. *Automatica*, 47:227–234, 2011.
- [8] D. Chen and B. Paden. Adaptive linearization of hybrid step motors: stability analysis. *IEEE Transactions on Automatic Control*, 38:874–887, 1993.
- [9] C.-L. Chen and Y.H. Yang. Position-dependent disturbance rejection using spatial-based adaptive feedback linearization repetitive control. *International Journal of Robust and Nonlinear Control*, 19:1337–1363, 2009.
- [10] W.D. Chen, K.L. Yung, and K.W. Cheng. A learning scheme for low-speed precision tracking control of hybrid stepping motors. *IEEE Transactions on Mechatronics*, 11:362–365, 2006.
- [11] L. Consolini and C.M. Verrelli. Learning control in spatial coordinates for the path-following of autonomous vehicles. *Automatica*, 50:1867–1874, 2014.
- [12] W.E. Dixon, E. Zergeroglu, D.M. Dawson, and B.T. Costic. Repetitive learning control: a Lyapunov-based approach. *IEEE Transactions on Systems, Man, and Cybernetics*, 32:538–545, 2002.
- [13] J. Holtz. Identification and compensation of torque ripple in high-precision permanent magnet motor drives. *IEEE Transactions on Industrial Electronics*, 43:309–320, 1996.
- [14] T.M. Jahns and W.L. Soong. Pulsating torque minimization techniques for permanent magnet AC motor drives - A review. *IEEE Transactions on Industrial Electronics*, 43:321–330, 1996.
- [15] H. Jin and J. Lee. An RMRAC current regulator for permanent-magnet synchronous motor based on statistical model interpretation. *IEEE Transactions on Industrial Electronics*, 56:169–177, 2009.
- [16] F. Khorrami, P. Krishnamurthy, and H.Melkote. *Modeling and Adaptive Nonlinear Control of Electric Motors*. Springer-Verlag, Berlin, 2003.
- [17] P. Krishnamurthy and F. Khorrami. Robust adaptive voltage-fed permanent magnet step motor control without current measurements. *IEEE Transactions on Control Systems Technology*, 11:415–425, 2003.
- [18] Y.-S. Kung and M.-H. Tsai. FPGA-based speed control IC for PMSM drive with adaptive fuzzy control. *IEEE Transactions on Power Electronics*, 22:2476–2486, 2007.
- [19] S. Li and Z. Liu. Adaptive speed control for permanent-magnet synchronous motor system with variations of load inertia. *IEEE Transactions on Industrial Electronics*, 56:3050–3059, 2009.
- [20] X. Li, J.-X. Xu, and D. Huang. Iterative learning control for nonlinear dynamic systems with randomly varying trial lengths. *International Journal of Adaptive Control and Signal Processing*, 29:1341–1353, 2015.
- [21] R.W. Longman. Iterative learning control and repetitive control for engineering practice. *International Journal of Control*, 73: 930–954, 2000.
- [22] Y. Luo, Y.Q. Chen, H.-S. Ahn, and Y. Pi. Dynamic high order periodic adaptive learning compensator for cogging effect in permanent magnet synchronous motor servo system. *IET Control Theory and Applications*, 5:669–680, 2011.
- [23] Y. Luo, Y.Q. Chen, and Y. Pi. Cogging effect minimization in PMSM position servo system using dual high-order periodic adaptive learning compensation. *ISA Transactions*, 49:479–488, 2010.
- [24] R. Marino, P. Tomei, and C.M. Verrelli. Robust adaptive learning control for nonlinear systems with extended matching unstructured uncertainties. *International Journal of Robust and Nonlinear Control*, 22:645–675, 2012.
- [25] R. Marino, P. Tomei, and C.M. Verrelli. Learning control for nonlinear systems in output feedback form. *Systems and Control Letters*, 61:1242–1247, 2012.
- [26] Y.A.-R.I. Mohamed. A hybrid-type variable-structure instantaneous torque control with a robust adaptive torque observer for a high-performance direct-drive PMSM. *IEEE Transactions on Industrial Electronics*, 54:2491–2499, 2007.
- [27] Y.A.-R.I. Mohamed. Design and implementation of a robust current-control scheme for a PMSM vector drive with a simple adaptive disturbance observer. *IEEE Transactions on Industrial Electronics*, 54:1981–1988, 2007.
- [28] F. Morel, J.-M. Rétif, X. Lin-Shi, and C. Valentin. Permanent magnet synchronous machine hybrid torque control. *IEEE Transactions on Industrial Electronics*, 55:501–511, 2008.
- [29] V. Petrović, R. Ortega, A.M. Stanković, and G. Tadmor. Design and implementation of an adaptive controller for torque ripple minimization in PM synchronous motors. *IEEE Transactions on Power Electronics*, 15:871–879, 2000.
- [30] W. Qian, S.K. Panda, and J.-X. Xu. Torque ripple minimization in PM synchronous motors using iterative learning control. *IEEE Transactions on Power Electronics*, 19:272–279, 2004.
- [31] W. Qian, S.K. Panda, and J.-X. Xu. Speed ripple minimization in PM synchronous motors using iterative learning control. *IEEE Transactions on Energy Conversion*, 20:53–61, 2005.
- [32] G.A. Ramos, J. Cortés-Romero, and H. Coral-Enriquez. Spatial observer-based repetitive controller: an active disturbance rejection approach. *Control Engineering Practice*, 42:1–11, 2015.
- [33] B. Sencer and E. Shamoto. Effective torque ripple compensation in feed drive systems based on the adaptive sliding-mode controller. *IEEE/ASME Transactions on Mechatronics*, 19: 1764–1772, 2014.

- [34] Y.X. Su, C.H. Zheng, and B.Y. Duan. Automatic disturbances rejection controller for precise motion control of permanent-magnet synchronous motors. *IEEE Transactions on Industrial Electronics*, 52:814–823, 2005.
- [35] K.W.-H. Tsui, N.C. Cheung, and K.C.-W. Yuen. Novel modeling and damping technique for hybrid stepper motor. *IEEE Transactions on Industrial Electronics*, 56:202–211, 2009.
- [36] J.-X. Xu. A new periodic adaptive control approach for time-varying parameters with known periodicity. *IEEE Transactions on Automatic Control*, 49:579–583, 2004.
- [37] J.-X. Xu, S.K. Panda, Y.-J. Pan, T.H. Lee, and B.H. Lam. A modular control scheme for PMSM speed control with pulsating torque minimization. *IEEE Transactions on Industrial Electronics*, 51:526–536, 2004.
- [38] J.-X. Xu and Y. Tan. Authors' reply [to comments on "A composite energy function-based learning control approach for nonlinear systems with time-varying parametric uncertainties"]. *IEEE Transactions on Automatic Control*, 48:1672–1674, 2003.
- [39] W.-S. Yao, M.-C. Tsai, and Y. Yamamoto. Implementation of repetitive controller for rejection of position-based periodic disturbances. *Control Engineering Practice*, 21:1226–1237, 2013.
- [40] M.S. Zaky. A self-tuning PI controller for the speed control of electrical motor drives. *Electric Power Systems Research*, 119: 293-303, 2015.