



UNIVERSITÀ DI PARMA

ARCHIVIO DELLA RICERCA

University of Parma Research Repository

Resorcinarene-based cavitands as building blocks for crystal engineering

This is the peer reviewed version of the following article:

Original

Resorcinarene-based cavitands as building blocks for crystal engineering / Pinalli, Roberta; Dalcanale, Enrico; Ugozzoli, Franco; Massera, Chiara. - In: CRYSTENGGCOMM. - ISSN 1466-8033. - 18:31(2016), pp. 5788-5802. [DOI:10.1039/C6CE01010E]

Availability:

This version is available at: 11381/2810627 since: 2021-09-29T12:57:30Z

Publisher:

Royal Society of Chemistry

Published

DOI:DOI:10.1039/C6CE01010E

Terms of use:

Anyone can freely access the full text of works made available as "Open Access". Works made available

Publisher copyright

note finali coverpage

(Article begins on next page)

Resorcinarene-based cavitands as building blocks for crystal engineering.

Received 00th January 20xx,
Accepted 00th January 20xx

DOI: 10.1039/x0xx00000x

www.rsc.org/

R. Pinalli, E. Dalcanale, F. Ugozzoli and C. Massera*

Since their first appearance on the chemistry scene thirty years ago, resorcinarene-based cavitands have been recognized to be a highly versatile class of compounds. Endowed with a rigid cavity of molecular dimensions, which can be decorated at the upper and lower rims with a variety of functional groups, they are efficient molecular receptors for chemical sensing, as well as tunable building blocks in the formation of covalent and supramolecular architectures. In this paper, we highlight and discuss “classic” and recent results concerning their chemistry, applications and crystal structure.

1. Introduction

Biological systems make use of molecular recognition between molecules that complement each other in shape, size, chemical functionalities and charge to accomplish many biological events, such as cellular communication, enzyme activity and antigen-antibody interaction, in a high efficient and specific way. Inspired by Nature, chemists design and prepare synthetic molecular receptors in order to explore the concepts of specificity, shape recognition and binding site complementarity, typical of the biological receptors. To harness the potential of synthetic receptors in molecular recognition requires structural information on the studied complexes in terms of type, number and strength of the involved interactions.

The concept of a close-surface receptor, capable to embrace organic or inorganic guests proposed by Don Cram in 1983,¹ was experimentally realized with the synthesis of the first carcerand, thanks to the covalent connection of two cavitands through four linkers.² By varying type and length of the linkers it was possible to modulate size, shape and dimensions of the lateral portals of the inner cavity. Carcerands were designed as a medium to include organic molecules, controlling their reactivity, dynamics and stability.³ Two selected examples worth mentioning are the taming of cyclobutadiene⁴ and the stabilization of *o*-benzyne.⁵ The metal-directed self-assembly approach was successively introduced into the chemical community by the pioneering work of Makoto Fujita in the early '90s.^{6,7} The transfer of this approach to the cavitand field produced coordination cages featuring reversibility and overcoming at the same time some of the synthetic limitations of the covalent route.

Cavitands, defined as concave organic molecules capable of molecular recognition,⁸ are one of the most fascinating and versatile class of chemical receptors derived from resorcinarenes. In the design of cavitands the choice of the bridging groups connecting the phenolic hydroxyls of the resorcinarene scaffold is pivotal, since it determines shape, dimensions and complexation properties of the resulting cavity (Figure 1.1). The selective binding of a guest by a molecular receptor to form a complex involves in fact, beside shape complementarity, the presence of specific weak interactions such as hydrogen bonding,⁹ π - π stacking,¹⁰ and CH- π interactions.¹¹ Much attention is currently devoted to the phosphorous derivatives of resorcinarenes, which have opened the route to promising pre-organized hosts.¹² Phosphorous groups play an important role in host-guest chemistry and because of their binding capabilities, they have been included in pre-organized structures to enhance the complexation properties of cavitands.

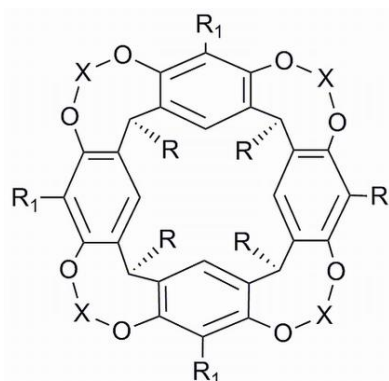

Figure 1.1 Molecular sketch of a generic resorcinarene based cavitand. **X** = bridging groups; **R₁** = upper rim substituents; **R** = lower rim substituents.

Dipartimento di Chimica and INSTM, UdR Parma, Università di Parma,
Parco Area delle Scienze 17/A, 43124 Parma, Italy. Email: chiara.massera@unipr.it

For this reason, the properties of the phosphoryl (P=O) and thiophosphoryl (P=S) moieties of binding neutral and cationic species have been extensively investigated.¹³⁻¹⁷

The inner space and functionality of cavitands can be tuned selecting the bridging units between the hydroxyl moieties, or inserting appropriate substituents at the upper rim. Many examples are present in the literature, like cavitands functionalized at the upper rim with aromatic bridging units,¹⁸ quinoxaline cavitands,^{19,20,21} crown cavitands,²² cavitands functionalized with tetraboronic pinacoyl esters,²³ or peptide- and protein-based cavitands.²⁴ The right choice of the apical functionalization or of the bridging units can also lead to the synthesis of multidentate cavitands acting as excellent platform for the self-assembly of coordination cages upon metal coordination.²⁵

All the above-mentioned features have contributed to the extensive and successful use of cavitands in molecular recognition processes. In addition to this, they have been fundamental in making these receptors outstanding building blocks for crystal engineering and for the formation of novel molecular architectures mediated by metal centres. In this review we will discuss these two last important applications of cavitand chemistry, focusing in particular to the examples reporting crystallographic analysis.

2. Cavitands and metals

The use of cavitands in combination with metals has produced an extensive literature in the past twenty years. Cavitands with different functionalizations can complex soft and hard metal centres, yielding both discrete complexes and extended frameworks. They are particularly used as pre-organized multidentate ligands, thanks to the possibility to introduce up to four substituents both at the upper and the lower rim. In addition to this, the cavity with which these macrocycles are endowed allows the creation of cages and capsules for different applications, as will be discussed in the following section.

2.1 Cavitand-based metal complexes

Numerous examples of crystal structures obtained combining cavitands and metals are present in the literature.²⁶⁻⁵² They span from discrete mono- and polymetallic complexes to more complicated coordination polymers, as depicted in Figures 2.1-2.4. The scope behind the synthesis and study of these species is rather diversified. In some cases, the incorporation of a metal centre inside the macrocycle has been used to modify the shape of the cavity and to change the recognition properties of the host.²⁶ In other cases, cavitand-metal complexes, in which the metal was embedded in the cavity, have been used as biomimetic models to evaluate the supramolecular effects on the metal ion properties and reactivity (**KOMKAA**, Figure 2.1).²⁷ The generation of new architectures with one or more cavitands connected through a metal centre has been realized synthesizing cavitands decorated both at the upper rim^{28a,b} and at the lower rim^{28c}

with groups suitable for metal complexation (See for instance **OCIWAY**,²⁹ **AQEQAP**,³⁰ **JOZUG** and **JOZLAN**³¹, Figure 2.1).

Some of the first results in this field of research were reported in the mid nineties by Puddephat and co-workers, who synthesized gold (**JUTYIG10**, Figure 2.1)³² and copper (**JUTYOM10**,³³ **REVBID**³⁴, Figure 2.1) phosphonite cavitands for size-selective inclusion of different guest ions, like amines,³² chlorine or iodine,³³ and for selective metal ion extraction from aqueous solution, suggesting potential applications also in the separation or purification of metal ions.

Similar P(III)-bridged cavitand complexes were obtained using gold (**MATRUU**, Figure 2.1),³⁵ silver and bromide (**EKUKUQ**, Figure 2.1)³⁶ or chloride counterions (**VASCIC**, Figure 2.1)³⁷ or copper (**XAMLUT**, Figure 2.1),³⁸ the latter two cases to study third-order nonlinear optical properties. The possibility of arranging coordinated metal ions in proximity to each other by means of the rigid scaffold offered by the macrocycle was realized by Harrison with the synthesis of a cavitand functionalized with four bis(pyridylmethylamine) moieties at the upper rim, able to coordinate four copper(II) centres (**MAPVEE**, Figure 2.1).³⁹

The complexation properties towards metal species of tetrabridged phosphonate (P=O) and thiophosphonated (P=S) cavitands has been extensively studied both by Dutasta's and Dalcanale's groups.⁴⁰ In all cases the phosphonate groups were positioned at the upper rim of the cavity as bridging groups, pointing inward in order to maximize the interactions between the host cavity and the guests. Indeed, the presence of an aromatic pre-organized cavity decorated with P=O or P=S groups capable of forming hydrogen bonds, CH- π and ion-dipole interactions has proved to be an effective tool for the encapsulation of different neutral molecules^{15a} or cations,⁴⁰ both in solution and at the solid state. Focusing the attention on the ability of these receptors to coordinate metal ions, the crystal structures of phosphonated cavitands with cesium (**VOSQAV**, Figure 2.2),^{40a} silver (**MIGVAZ**, Figure 2.2),^{40c} calcium (**CUYZOM**, Figure 2.2),^{40d} barium (**CUYZIG**, Figure 2.2)^{40d} and zinc (**CUYZUS**, Figure 2.2)^{40d} were reported. It is interesting to see how, in the case of thiophosphonate cavitands, the type of metal used for the complexation leads to 1:1 complexes as in the case of mercury^{40b} and thallium^{40b} in solution, or to a dimeric capsule in the case of Silver (**MIGVAZ**)^{40c}. Similarly, tetraphosphonate cavitands form a 1:1 complex with cesium,^{40a} and a 1:2 complex with barium,^{40d} calcium^{40d} and zinc^{40d}. In the case of the dimeric capsules,^{40d} it was elucidated that the coordination of the metal centre is governed by the metal cation size and by the propensity of the cavitand ligand to engage all P=O groups in the complexation through coordinated water, thus determining the formation of different architectures.

The complexation properties towards metal species of tetrabridged phosphonate (P=O) and thiophosphonated (P=S) cavitands exploit the advantage of the directionality that metal-ligand coordinative bonds offer with respect to weak interactions. Multidentate cavitand ligands can be synthesised in two ways: (i) functionalization at the apical positions and (ii) introduction of the ligands as bridging units.

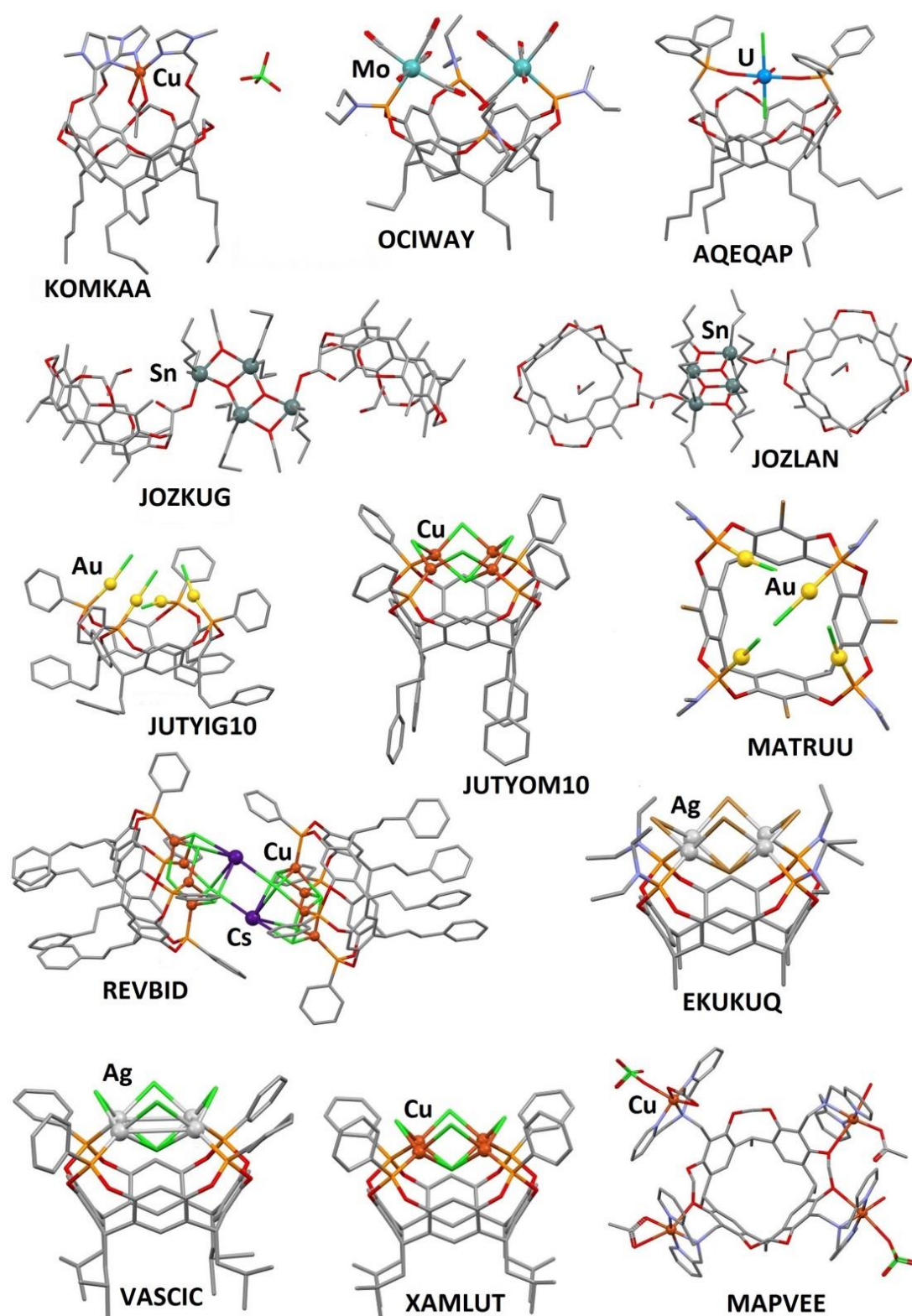

Figure 2.1 Overview of the molecular structures of some of the cavitand-metal complexes discussed in the paper, with their CSD reference code. Metal atoms are represented as spheres. Hydrogen atoms and solvent molecules have been omitted for clarity, as well as long alkyl chains and counterions, when necessary. Colour code: C, grey; O, red; N, blue; P, orange; Cl, green; Br, bronze.

These cavitands are particularly appealing building blocks for the formation of cages, as will be seen in paragraph 2.2, and of totally or partially open architectures, providing that suitable metals are used. For example, a cavitand with four pyrimidine substituents at the upper rim was used in combination with a palladium ethylenediamine nitrate complex to give either an interclipped supramolecular bowl or a intraclipped bowl (**TABKAJ**, Figure 2.2),⁴¹ depending on the solvent employed. In particular, a supramolecular capsule was formed as sole adduct in a mixture of chloroform/methanol while the bowl was obtained exclusively in aqueous phase. Using nitromethane, both the interclipped capsule and the intraclipped bowl were formed, a clear indication that self-assembly can be controlled by changing the solvent nature. Likewise, platinum, palladium and rhenium have been used to study the self-assembly of open ditopic and tetratopic cavitand complexes using monodentate cavitand ligands as building blocks, with the aim of predicting their self-assembly behavior.⁴² Only the crystal structures of the platinum complexes were obtained (**SAPZEP**, **SAPZIT**, **SAPZOZ**, Figure 2.2). The Authors demonstrated that depending on the *cis*-Pt complex used as metal precursor, both the monotopic and the ditopic-*trans* or ditopic-*cis* complexes could be obtained.

In some cases, the combined use of cavitands and metals have led to the formation of polymeric structures of different complexity. For instance, a 1-D polymeric chain was obtained mixing a cavitand decorated with four pyrimidyl rings at the upper rim with an hexafluoroacetylacetonate salt of Mn(II) (**YAPTOZ**, Figure 2.3).⁴³ The scope behind this study was to fine tune the formation of cages, 1-D or 2-D networks by changing the metal centres, and to obtain hollow materials that could perform uptake and release of small organic molecules, exploiting the intrinsic cavity of the macrocycle to impart porosity to the system. By mixing a tetra(phosphineoxide) cavitand with [Tb(DMSO)₈](CF₃SO₃)₃, an infinite 1-D polymer was also synthesized (**UTAVOB**, Figure 2.3) by Toupet and co-workers in 2011, showing consecutive cavitand units linked through two terbium ions, adopting a rare pentagonal bipyramidal coordination geometry.⁴⁴ More complex bilayer structures constructed by secondary building units were obtained using a flexible cavitand modified at the lower rim with four carboxylic groups. Different metal centres were used to assemble other types of coordination polymers, namely cadmium (**COKFUF**, Figure 2.3),⁴⁵ manganese (**COKGEQ**, Figure 2.3)⁴⁵ and zinc (**COKGAM**, Figure 2.3).⁴⁵ Using Cd, a trinuclear cluster was found, while infinite rod-shaped chains were observed in the case of Zn and Mn. These species showed interesting luminescence properties, making the cadmium and zinc analogues good candidates for sensing polyoxometallates in water.

Another important field of research in which cavitands have been involved is that of catalysis applied to organic synthesis. In recent years, the research group of Prof. Matt has produced several examples of catalytic intermediates comprising cavitand-metal species. Palladium complexes with resorcinarenyl monoimidazolium moieties (**LEYVAO**, Figure 2.4)⁴⁶ or with phosphinated resorcinarenes (**CUSFOM**, Figure

2.4)⁴⁷ have been used as catalyst precursors in Suzuki–Miyaura cross-coupling reactions. The Authors demonstrated that the catalytic outcome is influenced by the nature of the lower substituents which may transiently interact with the second coordination sphere of the metal, so to facilitate reductive elimination. Ruthenium (**KUYCEN** Fig 2.4),⁴⁸ (**SUFHEI**, Figure 2.4)⁴⁹ or nickel⁵⁰ resorcinarene-derived phosphanes have evidenced how cavitands can be cleaved regioselectively in the presence of a metal centre, yielding a “cracked cavitand” structure.

Finally, it is worth noting that, while all the above-mentioned structures show metals centres coordinating already-formed cavitands as ligands, only two examples exist in which the metal is used as bridging group at the upper rim for closing the macrocycle. Back in 1996, a tetrakis(zirconocene)calix(4)resorcinarene was reported by Floriani and coworkers (**ZUCXEA**, Figure 2.4)⁵¹ with the purpose of obtaining a polymetallic functionalizable skeleton and tuning the shape and binding properties of the cavity. The full metallation of the resorcinarene was successfully achieved using dialkyl or diaryl derivatives of Zr and Fe. The Authors showed through X-ray analysis that the four zirconium cations define an almost square framework anchored to the upper rim of the macrocycle. Similarly, four molybdenum atoms were inserted at the upper rim of a cavitand in the form of (3,5-dimethylpyrazolyl)borato-(nitroso)-molybdenum moieties (**NEFCOQ**, Figure 2.4)⁵² in order to introduce new recognition sites in the resorcinarene skeleton and to study intermolecular interactions involving the second coordination sphere of metal complexes. In particular, the Authors structurally identified a weak interaction between the dichloromethane guest and the coordinated nitric oxides. In spite of these two examples, the introduction of metals into the upper rim of cavitands as bridging units is severely hampered by the strain of the resulting metallocycle and by its low intrinsic stability. For these reasons this last approach has turned out to be by far less successful.

2.2 Cages

Cavitand-based cages have been synthesized by several research groups, either using metal-ligand coordinative bonds or weak intermolecular interactions as assembly tools, or, sometimes, a combination of the two. The techniques mostly employed to analyse the resulting products span from mass spectrometry, to NMR spectroscopy, to X-ray diffraction on single crystals. An exhaustive overview on resorcinarene-based capsules formed through H-bonds, metal-coordination bonds and dynamic covalent bonds has been recently published by Dalcanale²⁵ and Kobayashi.⁵³ In this paragraph we will principally deal with cages obtained *via* metal-cavitand coordination chemistry, with a special attention to the studies supported by crystallographic analysis. As shown in section 2.1, the possibility of introducing appropriate functional groups (carboxylate, pyridine, cyano, just to cite a few) as bridging units at the upper rim of the cavitands, make them suitable ligands for different types of metal centres.

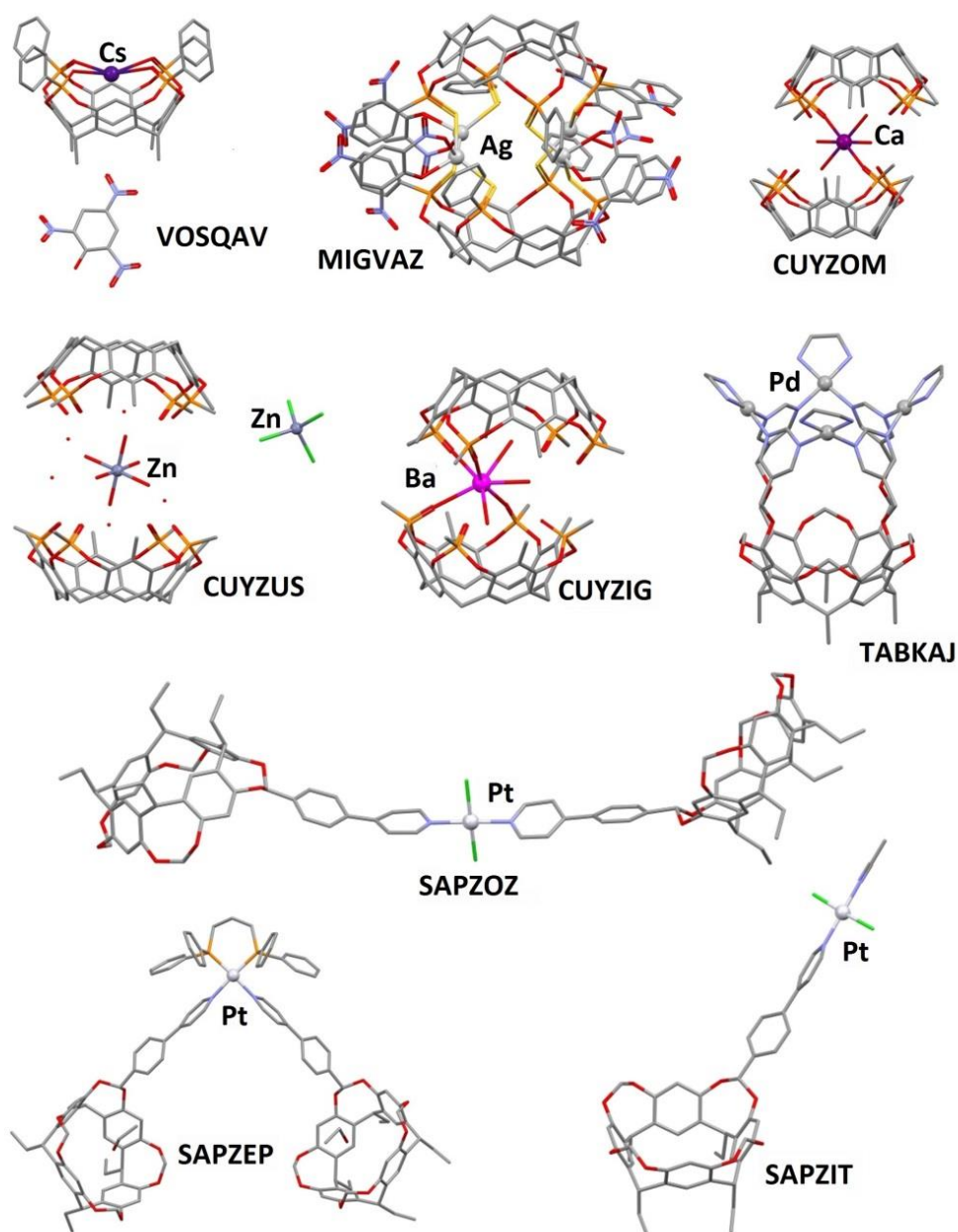

Figure 2.2 Overview of the molecular structures of some of the cavitand-metal complexes discussed in the paper, with their CSD reference code. Metal atoms are represented as spheres. Hydrogen atoms and solvent molecules have been omitted for clarity, as well as long alkyl chains and counterions, when necessary. Colour code: C, grey; O, red; N, blue; P, orange; S, yellow; Cl, green.

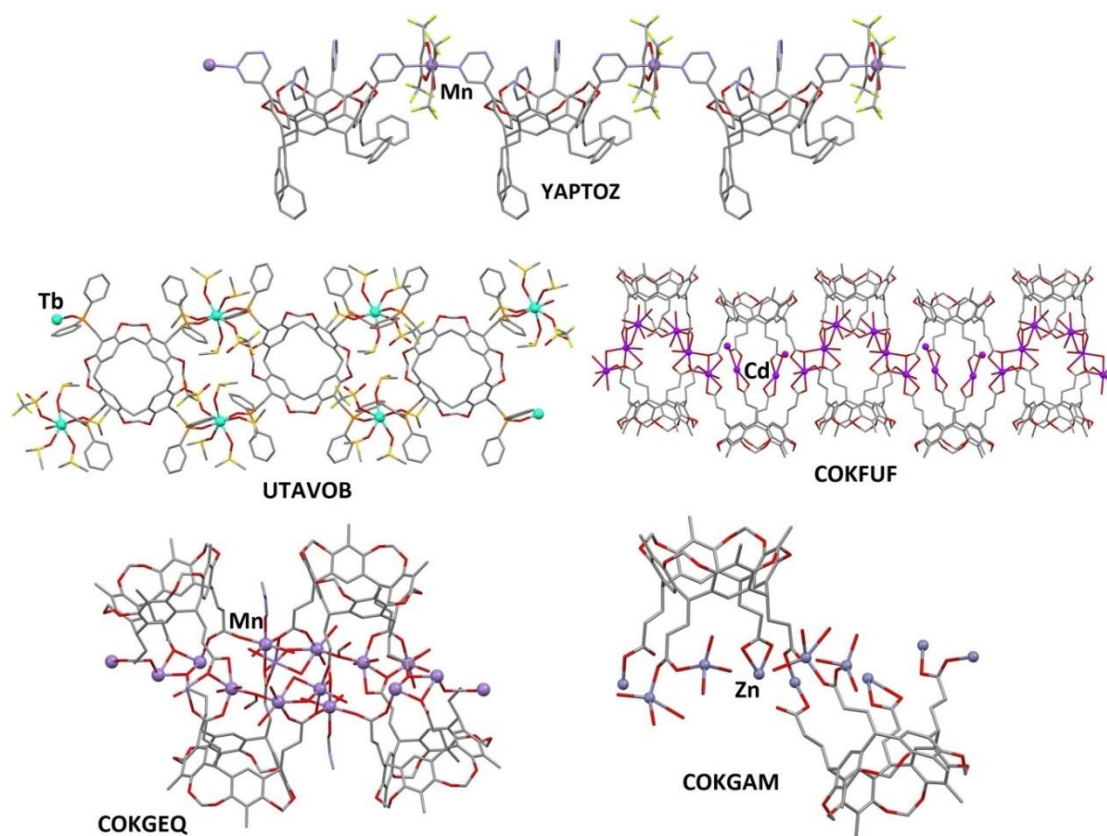

Figure 2.3 Overview of the coordination polymers discussed in the paper, with their CSD reference code. Metal atoms are represented as spheres. Hydrogen atoms and solvent molecules have been omitted for clarity, as well as counterions, when necessary. Colour code: C, grey; O, red; N, blue; F, green; S, yellow.

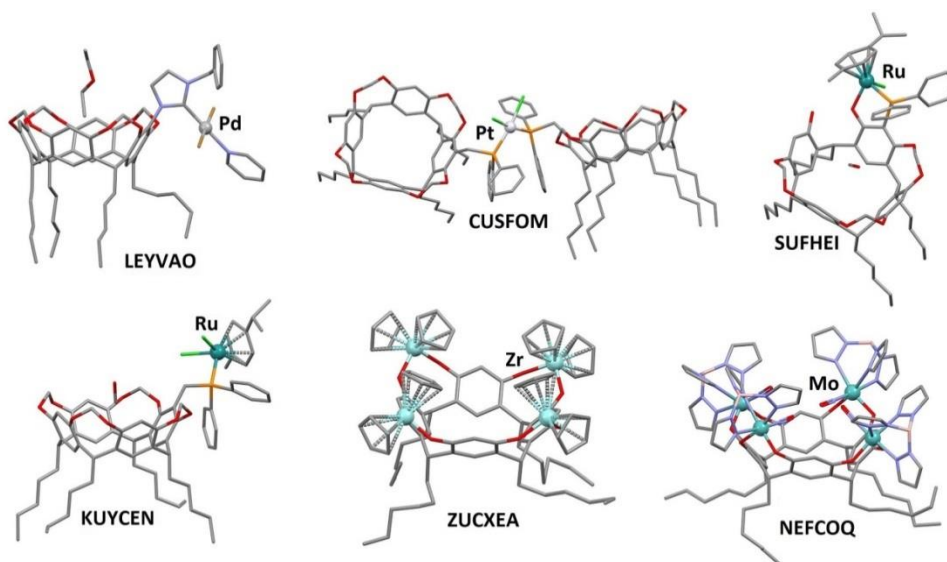
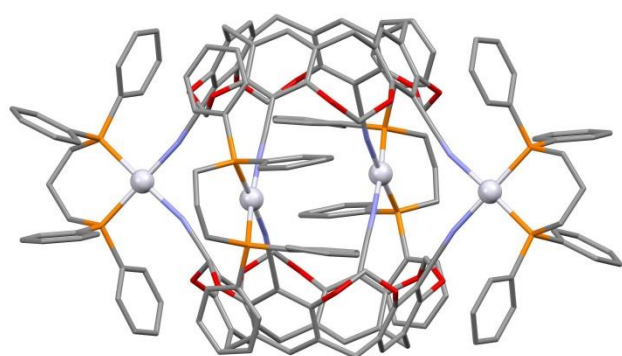

Figure 2.4 Overview of the coordination polymers discussed in the paper, with their CSD reference code. Metal atoms are represented in ball and stick mode. Hydrogen atoms and solvent molecules have been omitted for clarity, as well as counterions, when necessary. Colour code: C, grey; O, red; N, blue; Cl, green.

The choice of the functionalization is mostly dictated by the careful optimization of structural parameters such as the biting angle of the resulting multidentate ligand. One of the first papers reporting the synthesis of a new cavitand with this purpose in mind was that of Dalcanele and co-workers.^{54a} By mixing a tetracyano cavitand with four Pd (or Pt) square-planar complexes of the type $M(dppp)(triflate)_2$ they were able to obtain a dimeric capsule (**AFIRAI**, Figure 2.5) hosting a triflate counterion, as could be seen through NMR spectroscopy and X-ray diffraction analysis. A large set of coordination cages was prepared to elucidate the role played by: (i) the chelating ligand, (ii) the transition metal, (iii) the counterion of the metal precursor, (iv) the preorganization of the multidentate cavitand ligands in terms of conformational rigidity and relative orientation of the nitriles, (v) the ability to incorporate anions.^{54b}

Following this research line, many other examples of coordination cages were produced, mostly using palladium and platinum as metal centres. A cage was obtained using a cavitand bearing four pyridine moieties as bridging ligands, all preorganized in a diverging orientation.⁵⁵ In chlorinated solvents, the coordination cage was shown to form a 1:1 complex with methano[60]fullerene derivatives, driven by dispersion forces and π -stacking contacts between the guest and the inner surface of the host.⁵⁶

Analogous cavitands were also synthesized with longer substituents as bridging units, inserting four⁵⁷ phenylpyridyl arms, in order to obtain coordination cages of nanosize dimensions. The presence of the phenyl spacer did not change the self-assembly protocol, since the pyridine ligands retained the same diverging spatial orientation creating cages in presence of both Pd and Pt salts. A further example of a large coordination cage which exhibits inclusion properties has been described by Haino and co-workers.⁵⁸ They reported the self-assembly of a coordination cage using an octadentate cavitand functionalized at the upper rim with four bipyridyl (bipy) moieties able to bind four silver cations in a tetrahedral fashion.



AFIRAI

Figure 2.5 Molecular structure of the dimeric capsule (**AFIRAI**) obtained with platinum as metal centre. Colour code: P, orange; C, grey, O, red; N, blue, Pd, grey. Hydrogen atoms, solvent molecules, alkylic chains and triflate counterions have been omitted for clarity.

This cage showed unique encapsulation properties towards different carboxyl acids, derived from its size and shape. In 2003 Park reported the formation of a sole adduct by intralipping of resorcinarene-based ligands, functionalized at the upper rim with four pyridine moieties, with square planar Pd(II) ions in water.⁵⁹ The Authors demonstrated that the complexation processes of aromatic carboxylates are both enthalpy and entropy favoured.

Besides palladium and platinum, also lighter transition metals like cobalt and iron have been employed for the formation of cavitand-based cages. A first example was that reported by Harrison and co-workers,⁶⁰ who obtained a water soluble complex (**GIQJEV**), in which two resorcinarene molecules decorated at the upper rim with doubly deprotonated iminodiacetate moieties are held together by four cobalt(II) ions (Figure 2.6). The hydrophobic pocket offered by the cage is able to complex different guests, imposing size and shape selectivity.

Similar systems have been later synthesized also with iron.⁶¹ Thanks to NMR and X-ray crystallographic studies, these cages have been shown capable of binding and releasing guest organic molecules in water as a function of pH. Besides, the cages assembled into arrays giving rise to porous materials capable of absorbing and releasing water from the pores.⁶² Interestingly, the size and dimensions of the pores and channels can be controlled by the type of alkaline earth metal cations used for the assembly.⁶³

Bi-dentate cavitand ligands were used to study the possibility of obtaining oligomers of higher nuclearity and extended tridimensional frameworks by a judicious choice of different cavitand isomers and metal precursors, such as $[Re(CO)_5Br]$.⁶⁴ A first step toward the generation of a ligand/metal precursor library for the self-assembly of metal organic frameworks featuring embedded molecular recognition sites was done with phosphonate cavitands.

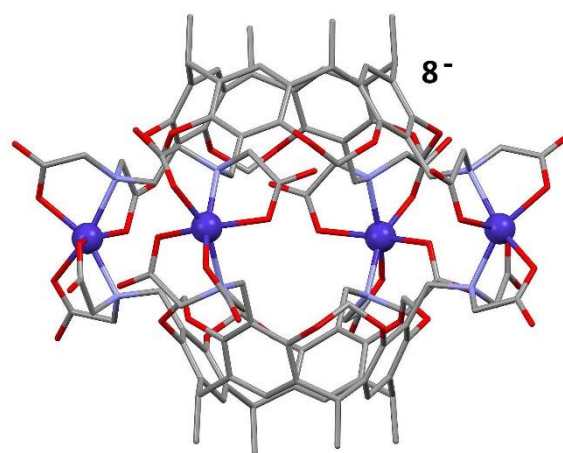

GIQJEV

Figure 2.6 Molecular structure of the octaanionic complex (**GIQJEV**) formed by two resorcinarene based cavitands and four Co(II) ions. Colour code: C, grey, O, red; N, light blue, Co, blue. Hydrogen atoms, solvent molecules, and counterions (barium and cobalt) have been omitted for clarity.

The molecular recognition properties of these cavitands bearing different numbers of P=O groups and those of the corresponding ditopic Re structures were investigated. It was shown that the number and spatial disposition of the P=O units are pivotal for the complexation of monotopic and ditopic N-methylpyridinium salts.⁶⁵

By changing parameters such as the coordination geometry of the metal employed and its oxidation state, not only cages, but also larger molecular containers can be assembled. For instance, mixing dithiocarbamate resorcinarene ligand units and zinc or copper ions, led to the formation of a trimeric $Zn_6(\text{cavitand})_3(\text{py})_6$ (**CUPKUT**) (Figure 2.7) and tetrameric $[Cu_8(\text{cavitand})_4]^{8+}$ host architecture, respectively.⁶⁶

The large inner cavity formed by these species has been shown to be suitable for binding spherical molecules like fullerene.⁶⁷ Along this line of research, Holman and co-workers were able to synthesize a nanocapsule (**VIXLAQ**) comprising six cavitands functionalized with four deprotonated carboxylic acids at the upper rim, and sixteen Zn(II) ions of general formula $[Zn_{16}(\text{cavitand})_6]^{8+}$ (Figure 2.8),⁶⁸ which further polymerize along the [001] direction *via* linear μ -hydroxy (or μ -oxo) linkages.

The data obtained *via* crystal structure analysis allowed to calculate the inner cavity volume and to show that the polymer is composed by hexameric, closed-surface metal-organic nanocapsules. Finally, a sodium complex was recently obtained using cavitands decorated with four guanine bases, to assemble a synthetic G-quadruplex of biological importance.⁶⁹ Structural details of G-quadruplexes are crucial for the elucidation and modulation of their functions, but are often problematic. In their work, the Authors demonstrated that the solid state analysis of the template-assembled G-quartet allowed the elucidation of the cavitand role as templating agent in simplifying the crystallization process.

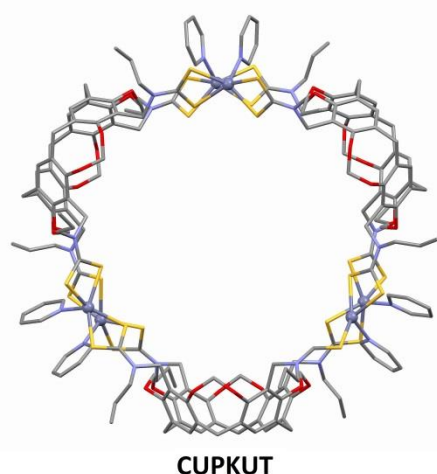

Figure 2.7 Molecular structure of the trimeric unit $[Zn_6(\text{cavitand})_3(\text{py})_6]$ (**CUPKUT**). The guest molecules and the alkyl chains at the lower rim of the cavitands have been removed for clarity. Zinc ions are represented as grey spheres.

3. Cavitands as building blocks for capsules and supramolecular polymers

The possibility of functionalizing cavitands both at the upper and lower rim, makes these class of molecules versatile supramolecular synthons for the rational formation of discrete and/or polymeric assemblies, depending on the choice of the building blocks and on the type of interactions involved.⁷⁰ This research field has been strongly influenced by all the work accomplished on cavitands as molecular receptors, and by self-folding and self-assembly mediated by inclusion processes. As in the case of cavitands and metals, most of the attention was given to the design of molecular assemblies to be used in different applications spanning from catalysis to sensing.⁵³

One of the first examples of a dimeric capsule held together by self-complementary H-bonds was provided by Rebek and co-workers, employing cavitands decorated at the upper rim with bis-glycoluril units,⁷¹ or imine-pyrazine bridge cavitands.⁷² In this last study the Authors explored the size- and shape-selectivity of the encapsulation process and introduced the concept of optimal occupancy volume.^{72,73}

They observed the exclusive formation of the hetero-guest pair when benzene and *p*-xylene were both added to a solution of the host, presumably because two benzene guests left too much empty space in the interior of the cavity, while two *p*-xylene molecules made it too crowded.

A great asset for understanding the assembly process is the analysis of the solid state structures of these systems provided by X-ray diffraction on single crystals. As in the case of metallocages, this paragraph will primarily focus on examples obtained employing this investigation technique.

Back in 1998, Sherman reported the crystal structure of molecular capsules assembled *via* four charged hydrogen bonds, combining a tetramethylene bridged cavitand bearing four OH groups on the apical position of the aromatic rings with its deprotonated analogue, in the presence of DBU as base and pyrazine as guest.⁷⁴ The solution and solid state characterization provided unprecedented details for such complexes, particularly with respect to the orientation and mobility of the encapsulated guests. Since then, several new cavitands have been synthesized to this purpose, often by introducing self-complementary hydrogen bond donor and acceptor sites along the upper rim.

For example, dimeric H-bonded capsules were obtained starting with different tetraimide,⁷⁵ tetraester⁷⁶ or with tetra- or triamide cavitands.⁷⁷ The dimerization process in these cases was driven not only by the formation of hydrogen bonds but also by the self-inclusion of moieties of one cavitand into the deep cavity of an adjacent one.

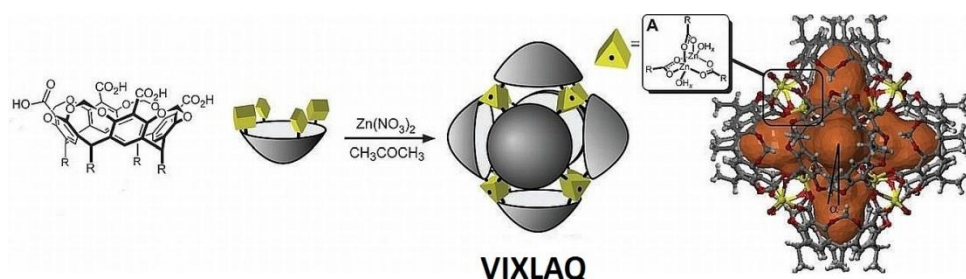

Figure 2.8 Assembly of the $[Zn_{16}(\text{cavitand})_6]^{8+}$ nanocapsule **VIXLAQ**. The solvent accessible internal cavity volume is shown in orange. The phenethyl substituents of the cavitaand are represented as methyl groups for clarity. Reproduced with permission of The Royal Society of Chemistry from Ref. 68.

Pursuing a similar line of research, Kobayashi and his research group first reported that methylene-bridged cavitaands decorated with four carboxy groups at the upper rim produced a wave-ladder type of 1-D hydrogen-bonded network, showing a very porous crystal packing.⁷⁸ In a subsequent study they demonstrated that by combining two molecules of tetracarboxylic acid cavitaands with four molecules of 2-aminopyrimidine a capsule was formed (**KAHMOV**), assembled *via* 16 hydrogen bonds, and hosting two molecules of nitrobenzene (Figure 3.1. Guests are not shown for clarity).⁷⁹

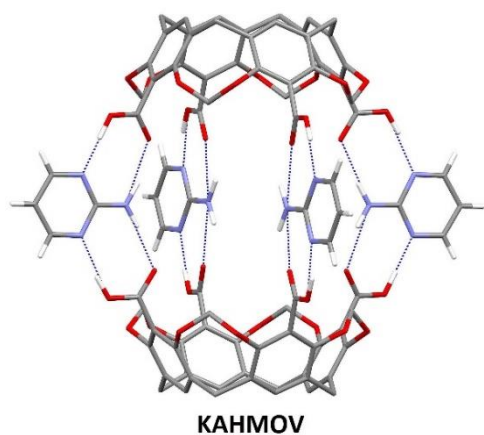

Figure 3.1 Molecular structure of the hydrogen-bonded capsule **KAHMOV**. Colour code: C, grey, O, red; N, light blue; H-bonds, blue dotted lines. Only the hydrogen atoms involved in the weak interactions are shown. Alkyl chains and guest molecules have been omitted for clarity.

Very recently, a similar capsule has been obtained from two tetrakis(4-pyridylethynyl)cavitaands and a porphyrin ring, mediated by eight hydrogen bonds.⁸⁰ By mixing 2 molecules of cavitaand and 1 molecule of porphyrin, Kobayashi and co-workers were able to obtain a doubly cavitaand-capped porphyrin capsule 2·1·2 assembled *via* eight $\text{ArOH}\cdots\text{Npy}$ hydrogen bonds, possessing two cavities separated by the porphyrin ring. It was shown that each cavity could accommodate a guest molecule and that a remarkable solvent effect was present for guest encapsulation, with deuterated benzene being a better solvent for the capsule formation than CDCl_3 .

Kobayashi also implemented an alternative strategy to obtain supramolecular heterodimeric capsules using cavitaands functionalized with carboxylic or pyridyl groups able to interact in a rim-to-rim fashion *via* four intermolecular $\text{CO}_2\text{H}\cdots\text{N}$ hydrogen bonds.⁸¹ In particular, by assembling together a tetracarboxyl-cavitaand with a tetra(3-pyridyl)-cavitaand, the 1:1 heterodimeric capsule **ILIJOC** was obtained (Figure 3.2).

The assembly process was shown to be specifically induced by 1,4-disubstituted-benzene guests, as demonstrated by X-ray diffraction analysis on single crystals and by NMR studies in solution. The ability of the guest to induce the heterodimeric capsule assembly and the orientational isomerism of the encapsulated, non-symmetrical *p*-disubstituted-benzene guests were elucidated. In the case of similar heterodimeric capsules formed by tetra(4-pyridyl)-cavitaands and tetrakis(4-hydroxyphenyl)-cavitaands through four $\text{PhOH}\cdots\text{pyridyl}$ hydrogen bonds,⁸² the orientation of the 1,4-disubstituted-benzene guest inside the capsule cavity was also confirmed *via* X-ray crystallographic analysis.



Figure 3.2 Molecular sketch of the hydrogen-bonded capsule **ILIJOC**, held together by four intermolecular $\text{CO}_2\text{H}\cdots\text{N}$ hydrogen bonds. $\text{R}=(\text{CH}_2)_6\text{CH}_3$ or $\text{R}=(\text{CH}_2)_2\text{Ph}$. Reproduced with permission from Ref. 81a. Copyright (2003) American Chemical Society.

The delicate balance among attractive $\text{CH}-\pi$ interactions, $\text{CH}-\text{halogen}$ (halogen- π) interactions, $\text{C}=\text{O}\cdots\text{HC}$ interactions, and the electrostatic potential repulsion between the lone pair of the carbonyl oxygen atom of the guest and the aromatic cavity of the host, was found to influence the binding ability of the guests to the capsule, as well as the orientational isomeric selectivity of unsymmetrical guests. The binding constants in various solvents and the overall stability of the heterocapsule in the presence of different aromatic guests were studied and reported by Kobayashi's group in 2013.⁸³ The thermodynamic analyses revealed that the complex formation was both enthalpy and entropy driven. The same systems also provided an interesting example of a supramolecular gyroscope, with the aromatic guest rotating inside the cage along its vertical axis.⁸⁴

In order to construct supramolecular capsules, Aakeröy and co-workers have synthesized several new cavitand-based building blocks by introducing tailored H-bond acceptor or donor groups at the upper rim of the cavitands.⁸⁵

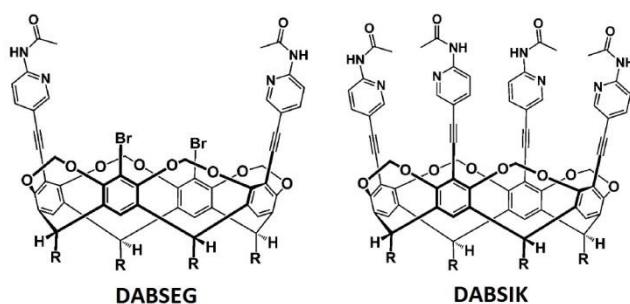

Figure 3.3 C-Pentyl-1,3-dibromo-2,4-di(2-acetamidopyridyl-5-ethynyl)-cavitand **DABSEG** (left) and C-pentyl-tetra(2-acetamidopyridyl-5-ethynyl)cavitand **DABSIK** (right). $\text{R}=(\text{CH}_2)_4\text{CH}_3$. Reproduced permission of The Royal Society of Chemistry from Ref. 86.

By inserting two or four self-complementary hydrogen-bonding moieties, namely 2-acetamidopyridyl-5-ethynyl groups, at the upper rim, they obtained either the 1,3-bifunctionalized cavitand **DABSEG** or the tetra-functionalized analogue **DABSIK** (Figure 3.3) which yielded, a supramolecular 1-D polymer and a discrete capsule, respectively (Figure 3.4).⁸⁶ In both cases, the structures were held together via $\text{N}-\text{H}\cdots\text{O}$ hydrogen bonds. The addition of the ethynyl groups at the cavitand upper rim increased the depth of the receptor and its interior electron density, thus enhancing the binding to suitable electron-poor guests of considerable size. Similarly, a supramolecular heterodimeric capsule (**DEGWET**) held together by four $\text{I}\cdots\text{N}$ halogen bonds was successfully obtained assembling a tetra(3-pyridyl)cavitand with a tetra(4-iodotetrafluorophenyl) calix[4]arene (Figure 3.5).⁸⁷

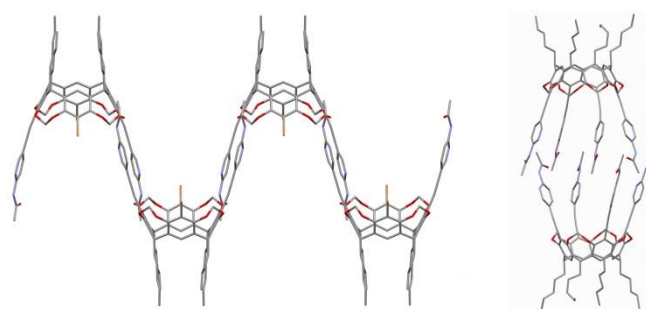

Figure 3.4 Left: the polymeric 1D chain formed by cavitand **DABSEG**. Right: the capsule formed by cavitand **DABSIK** through $\text{N}-\text{H}\cdots\text{O}=\text{C}$ hydrogen bond interactions.

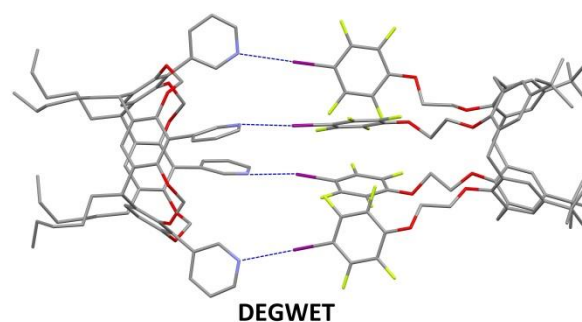

Figure 3.5 Molecular structure of the dimeric capsule (**DEGWET**) assembled *via* four $\text{I}\cdots\text{N}$ halogen bonds (blue dotted lines). Colour code: C, grey; O, red; N, blue; F, yellow; I, purple. Hydrogen atoms and solvent molecules have been omitted for clarity.

These specific synthons were expressly selected to combine advantageously the pre-organization brought by the rigid cavitant structure, with the conformational flexibility given by the lower-rim chains of the calixarene. In spite of this flexibility, in 40% of the cases a partially open capsule with only three I...N interactions was obtained, due to the steric hindrance generated by the four iodotetrafluorophenyl arms. However, halogen bond was demonstrated to be an effective tool to form strong and directional interactions also for these types of systems. In this respect, Rissanen and co-workers have recently reported the crystal structure of the adducts of tetraiodoethyl cavitands with 1,4-dioxane, pyridine, and tetrapropyl ammonium bromide respectively, highlighting the ability of iodine to interact with different halogen bond acceptors.⁸⁸ These results demonstrate the usefulness of the resorcinarene skeleton to act as a platform for the construction of new 3-D cavitant-based halogen bonded supramolecular assemblies. Molecular capsules based solely on the interaction of halogen bonding have been recently studied in solution by Diederich and co-workers.⁸⁹

The presence of specific functions at the upper or lower rims of the cavitands can also be exploited to use these macrocycles as moulds to create a pre-organized pattern, and to induce geometrical spatial arrangements in the solid state. This has been recently shown by means of a tetraphosphonate cavitant (**YUFBUX**), in which the specific H-bond interaction pattern induced by the host *via* its rigid pre-organized platform of four P=O acceptor groups led to the exclusive formation of a cyclic water tetramer with C₄ symmetry (Figure 3.6).⁹⁰

Tetraphosphonate cavitands have demonstrated remarkable molecular recognition properties toward N-methyl ammonium salts both in liquid,¹⁶ and in the solid state.¹⁷ The origin of the receptor selectivity toward N-methyl ammonium salts is attributed to the presence of three interaction modes: (i) N⁺...O=P cation-dipole interactions; (ii) CH₃-π interactions of the acidic ⁺N-CH₃ group with the π basic cavity; (iii) two simultaneous hydrogen bonds between two adjacent P=O bridges and the two nitrogen protons.

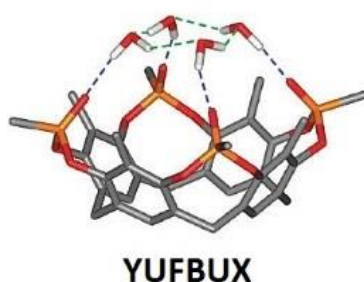

Figure 3.6 Side view of the tetraphosphonate cavitant **YUFBUX** with the induced cluster of hydrogen-bonded water molecules (Colour code: P, orange; O, red; C, grey; H, white; weak intermolecular interactions, blue and green). Reproduced with permission of The Royal Society of Chemistry from Ref. 90.

For these outstanding and versatile molecular recognition properties, tetraphosphonate cavitands are extremely appealing for the formation of supramolecular polymers *via* host-guest interactions. The introduction of both host and guest units in the same monomer was the strategy used by Dalcanale and co-workers to induce the self-assembly of supramolecular polymers.⁹¹ The desired monomer presented a single methylpyridinium unit (**POBLIC**, Figure 3.7) at the lower rim of a tetraphosphonate cavitant, to exclude the possibility of self-association.

By inclusion of the methylpyridinium unit in the cavity of an adjacent cavitant, a linear homopolymer was formed, self-assembled *via* multiple ion-dipole interactions between the P=O groups and the positively charged methylpyridinium moiety, and CH-π interactions between the acidic methyl group and the π-basic cavity, as demonstrated by solid state studies. In the crystal, the polymer assumes a straight and extended (all-transpyridinium linker) conformation. (Figure 3.8).

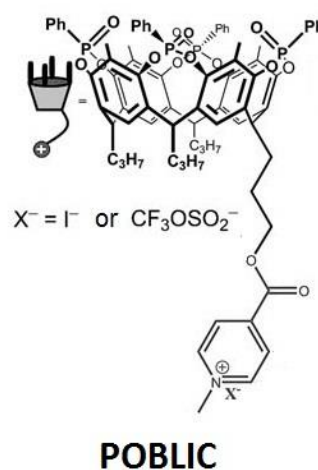

Figure 3.7 Structure of the monomer **POBLIC** employed for the polymerization process. Reproduced with permission from Wiley-VCH Ref. 91.

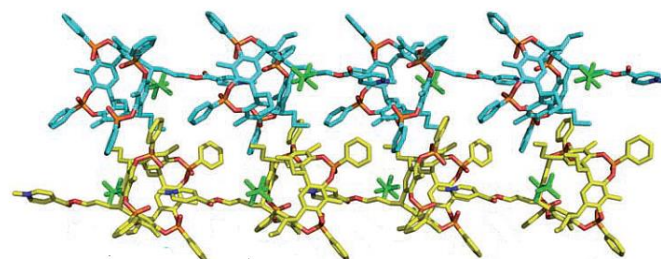

Figure 3.8 Crystal structure of the supramolecular polymer formed by **POBLIC**, showing two independent chains (blue and yellow). The triflate counterion is depicted in green. Reproduced with permission from Wiley-VCH Ref. 91.

The supramolecular plasticity of these polymers was proven by addition of a porphyrin molecule bearing four pyridinium moieties, which led to the quantitative formation of a star-branched polymer.

By inserting the methylpyridinium unit at the upper rim in replacement of one P=O group,⁹¹ a self-inclusion dimer was observed instead, both in solution and in the solid state.⁹²

A similar self-inclusion dimeric capsule has been recently described by Kobayashi⁹³ using a cavitand decorated by 2,2'-bipyridyl pillars on its upper rim. In this case, the dimeric capsules that encapsulate small guests, such as nitromethane, acetonitrile or methyl acetate, are formed through the π - π stacking of the flat bipyridyl moieties.

An alternative approach to obtain supramolecular copolymers, requires the distribution of the self-assembling functionalities in two different species. Homoditopic complementary host-guest units were reported by Dalcanale's group in 2010. A di-topic host consisting of two tetraphosphonate cavitands covalently linked at their lower rim was reacted with a di-topic guest consisting of flexible ethylene oxide chains of different length, functionalized with two N-methylpyridinium end groups (Figure 3.9).⁹⁴ Both linear and cyclic copolymers were thus obtained, the length of the chains and the solvent used influencing the thermodynamics of the system.

In the case of flexible polymers, formed by the self-assembly of a di-topic host featuring an adipic spacer connecting the cavitand units, and di-topic guest bearing a polyethylene glycol linker, viscosimetry studies revealed the presence of a ring-chain equilibrium, converging to the formation of linear polymeric species in high concentration systems. In the case of rigid systems, obtained *via* self-assembly of a di-topic host bearing an aromatic unit as linker and a methyl viologen as di-topic guest, the X-ray analysis provided a physical evidence of the formation of a linear structure (Figure 3.10).

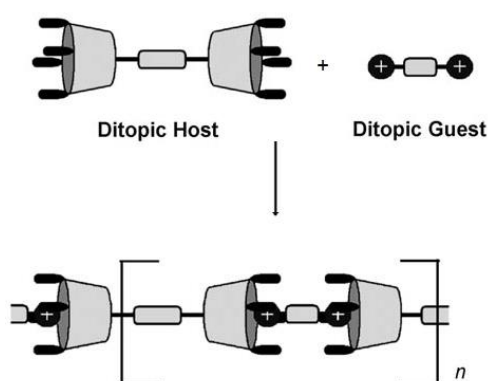

Figure 3.9 The host-guest polymerization mode. Reproduced with permission from Wiley-VCH Ref. 94.

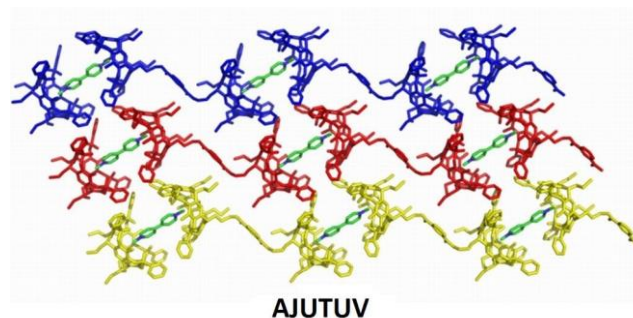

Figure 3.10 Structure of the co-polymer **AJUTUV** obtained by self-assembly of the ditopic cavitand host and the methyl viologen di-topic guest. Reproduced with permission from Wiley-VCH Ref. 94.

Conclusions

We have reviewed some aspects of the rich chemistry of resorcinarene-based cavitands, focussing on the solid state structures of their supramolecular assemblies and metal complexes. The key feature of cavitands is the presence of a pre-organized, π -basic cavity which can be decorated both at the upper and lower rim with a great variety of functional groups making them ideal building blocks for crystal engineering and coordination chemistry. The mastering and tailoring of weak interactions (metal coordination, H-bonding, solvophobic and CH- π interactions, etc.) has been shown to be of primary importance for the generation of functional materials; in this respect, the study of crystal structures through X-ray diffraction has proved to be a fundamental tool for understanding, in the solid state, the interactions responsible of the desired functions/organization. The detailed knowledge of the complex structure reveals the molecular origin of the implemented function, allowing rational refinement of the functional groups and their positioning/orientation in order to maximize the desired interactions. Moreover, in the case of molecular containers, the solid state studies allow to calculate and shape the inner cavity size according to the desired guest or to model the cavity required functions.

Compared to the vast literature on self-assembled cages and containers, fewer examples exist of tridimensional arrays based on cavitands. Very interesting would be the possibility of synthesizing extended materials showing macroporosity in their crystal structure while retaining the inherent microporosity of the molecular cavity.^{43, 95} As summarized in this review, the shape, dimension and nature of the receptor and consequently the host-guest interactions can be tuned by the choice of the bridging groups at the upper rim of the resorcinarene scaffold. The versatile sensing properties of cavitands can be harnessed in molecular recognition in the solid state when the receptors are properly arranged in a solid matrix. The functionalization of the lower rim of the cavitands with suitable ligands would allow the insertion of these receptors into tridimensional structures, so tuning the recognition properties of the porous material.^{28c} This would

be of interest for many practical applications, spanning from sensing, to absorption and storage.

Acknowledgements

It is a pleasure to acknowledge all co-workers whose work provided the basis of this review. Their names appear in the reference section. This work was supported over the years by MIUR through PRIN and FIRB projects and by the EU through FP6, FP7 and H2020 programs.

Notes and references

- 1 D. J. Cram, *Science* 1983, **219**, 1177.
- 2 D. J. Cram, S. Karbach, Y. H. Kim, L. Baczynskij and G. W. Kalleymeyn, *J. Am. Chem. Soc.* 1985, **107**, 2575.
- 3 A. Jasat and J. C. Sherman, *Chem. Rev.* 1999, **99**, 931.
- 4 D. J. Cram, M. E. Tanner, R. Thomas, *Angew. Chem. Int. Ed. Eng.* 1991, **30**, 1024.
- 5 R. Warmuth, *Angew. Chem. Int. Ed. Eng.* 1997, **36**, 1347.
- 6 M. Fujita, J. Yazaki and K. Ogura, *J. Am. Chem. Soc.* 1990, **112**, 5645.
- 7 M. Fujita, *Chem. Soc. Rev.* 1998, **27**, 417.
- 8 D. J. Cram., J. M Cram *Container Molecules and their Guests, Monographs in Supramolecular Chemistry*, Vol 4 (Ed.: J F. Stoddart), Royal Society of Chemistry, Cambridge 1994.
- 9 J. Rebek Jr., *Angew. Chem. Int. Ed. Engl.* 1990, **29**, 245.
- 10 C. H. Hunter, K. R. Lawson, J. Perkins and C. J. Urch, *J. Chem. Soc., Perkin Trans. 2*, 2001, 651.
- 11 M. Nishio, M. Hirota and Y. Umezawa, *The CH- π Interactions*, Wiley-VCH, New York, 1998.
- 12 R. Pinalli and E. Dalcanale, *Acc. Chem. Res.*, 2013, **46**, 399.
- 13 a) R. Pinalli, F. F. Nachtigall, F. Ugozzoli and E. Dalcanale, *Angew. Chem., Int. Ed.*, 1999, **38**, 2377; b) F. Maffei, P. Betti, D. Genovese, M. Montalti, L. Prodi, R. De Zorzi, S. Geremia and E. Dalcanale, *Angew. Chem. Int. Ed.*, 2011, **50**, 4654.
- 14 M. Suman, M. Freddi, C. Massera, F. Ugozzoli and E. Dalcanale, *J. Am. Chem. Soc.* 2003, **125**, 12068.
- 15 a) M. Melegari, M. Suman, L. Pirondini, D. Moiani, C. Massera, F. Ugozzoli, E. Kalenius, P. Vainiotalo, J.-C. Mulatier, J.-P. Dutasta and E. Dalcanale, *Chem. Eur. J.* 2008, **14**, 5772; b) R. De Zorzi, G. Brancatelli, M. Melegari, R. Pinalli, E. Dalcanale and S. Geremia, *CrystEngComm*, 2014, **16**, 10987.
- 16 a) R. De Zorzi, B. Dubessy, J.-C. Mulatier, S. Geremia, L. Randaccio and J.-P. Dutasta, *J. Org. Chem.*, 2007, **72**, 4528.; b) R. M. Yebeutchou and E. Dalcanale, *J. Am. Chem. Soc.* 2009, **131**, 2452; c) D. Menozzi, E. Biavardi, C. Massera, F. P. Schmidtchen, A. Cornia and E. Dalcanale, *Supramol. Chem.* 2010, **22**, 768.
- 17 a) E. Biavardi, M. Favazza, A. Motta, I. L. Fragalà, C. Massera, L. Prodi, M. Montalti, M. Melegari, G. Condorelli and Enrico Dalcanale, *J. Am. Chem. Soc.*, 2009, **131**, 7447; b) M. Dionisio, G. Oliviero, D. Menozzi, S. Federici, R. M. Yebeutchou, F. P. Schmidtchen, E. Dalcanale and P. Bergese, *J. Am. Chem. Soc.* 2012, **134**, 2392.
- 18 a) H. Xi, C. L. D. Gibb, E. D. Stevens and B. C. Gibb, *Chem. Commun.*, 1998, 1743; b) D. M. Rudkevich, G. Hilmersson, and J. Rebek Jr., *J. Am. Chem. Soc.* 1998, **120**, 12216; c) B. W. Purse, S. M. Butterfield, P. Ballester, A. S. hivanyuk and J. Rebek Jr., *J. Org. Chem.*, 2008, **73**, 6480.
- 19 a) J. R. Moran, S. Karbach and D. J. Cram, *J. Am. Chem. Soc.* 1982, **104**, 5826; b) E. Dalcanale, P. Soncini, G. Bacchilega and F. Ugozzoli, *J. Chem. Soc. Chem. Commun.*, 1989, 500; c) P. Soncini, S. Bonsignore, E. Dalcanale and F. Ugozzoli, *J. Org. Chem.*, 1992, **57**, 4608.
- 20 a) J. Hornung, D. Fankhauser, L. D. Shirtcliff, A. Praetorius, W. B. Schweizer and F. Diederich, *Chem.-Eur. J.*, 2011, **17**, 12362; b) F. Bianchi, A. Bedini, N. Riboni, R. Pinalli, A. Gregori, L. Sidisky, E. Dalcanale and M. Careri: *Anal. Chem.* 2014, **86**, 10646; c) J. Trzcinski, R. Pinalli, F. Bianchi, C. Massera and E. Dalcanale, *Eur. Pat. Appl.* 2015, EP 2924041 A1 20150930; d) N. Riboni, J. W. Trzcinski, F. Bianchi, C. Massera, R. Pinalli, L. Sidisky, E. Dalcanale, and M. Careri *Analytica Chimica Acta* 2016, **905**, 79; e) F. Bertani, N. Riboni, F. Bianchi, G. Brancatelli, E. S. Sterner, R. Pinalli, S. Geremia, T. M. Swager and E. Dalcanale, *Chem. Eur. J.* 2016, **22**, 1.
- 21 F. C. Tucci, D. M. Rudkevich and J. Rebek Jr. Jr, *J. Org. Chem.*, 1999, **64**, 4555.
- 22 I. Higler, H. Boerrigter, W. Verboom, H. Kooijman, A. L. Spek and D. N. Reinhoudt, *Eur. J. Org. Chem.*, 1998, 1597.
- 23 C. B. Aakeröy, P. D. Chopade, N. Schultheiss and J. Desper, *Eur. J. Org. Chem.*, 2011, 6789.
- 24 a) C. Berghaus and M. Feigel, *Eur. J. Org. Chem.*, 2003, 3200; b) J. O. Freeman, M. E. P. Murphy, J. C. Sherman, *Chem.-Eur. J.*, 2012, **18**, 11409.
- 25 R. Pinalli, F. Boccini and E. Dalcanale, *Isr. J. Chem.*, 2011, **51**, 781.
- 26 U. Lücking, J. Chen, D. M. Rudkevich and J. Rebek Jr., *J. Am. Chem. Soc.*, 2001, **123**, 9929.
- 27 J. Gout, A. Višnjevac, N. Le Poul, Y. Le Mest and O. Reinaud, *Inorg. Chem.*, 2014, **53**, 6224.
- 28 a) K. E. Djernes, O. Moshe, M. Mettry, D. D. Richards and R. J. Hooley, *Org. Lett.*, 2012, **14**, 788; b) N. A. Shamsutdinova, S. N. Podyachev, S. N. Sudakova, A. R. Mustafina, R. R. Zairov, V. A. Burilov, I. R. Nizameev, I. K. Rizvanov, V. V. Syakaev, B. M. Gabidullin, S. A. Katsuba, A. T. Gubaidullin, G. M. Safiullin and W. Dehaen, *New J. Chem.*, 2014, **38**, 4130; c) K. Misztal, A. Sartori, R. Pinalli, C. Massera and E. Dalcanale, *Supramol. Chem.*, 2014, **26**, 151.
- 29 E. E. Nifant'ev, V. I. Maslennikova, S. E. Goryukhina, M. Y. Antipin, K. A. Lyssenko and L. K. Vasyanina, *J. Organomet. Chem.*, 2001, **631**, 1.
- 30 H. E. Moll, D. Sémeril, D. Matt and L. Toupet, *Z. Kristallogr.-New Cryst. Struct.*, 2011, **226**, 91.
- 31 Y.-B. Dong, H.-Y. Shi, J. Yang, Y.-Y. Liu and J.-F. Ma, *Cryst. Growth Des.*, 2015, **15**, 1546.
- 32 W. Xu, J. P. Rourke, J. J. Vittal and R. J. Puddephatt, *Inorg. Chem.*, 1995, **34**, 323.

- 33 W. Xu, J. J. Vittal and R. J. Puddephatt, *J. Am. Chem. Soc.*, 1995, **117**, 8362.
- 34 W. Xu, J. J. Vittal and R. J. Puddephatt, *Inorg. Chem.*, 1997, **36**, 86.]
- 35 P. Sakhaii, I. Neda, M. Freytag, H. Thonnessen, P. G. Jones and R. Schmutzler, *Z. Anorg. Allg. Chem.*, 2000, **626**, 1246
- 36 V. I. Maslennikova, O. S. Serkova, L. K. Vasyanina, K. A. Lyssenko, M. Yu. Antipin and E. E. Nifantsev, *J. Organomet. Chem.*, 2003, **677**, 21.
- 37 S. Miao, W.-R. Yao, D.-S. Guo and Q.-F. Zhang, *J. Mol. Struct.*, 2003, **660**, 159.
- 38 Q.-F. Zhang, R. D. Adams and D. Fenske, *J. Mol. Struct.*, 2005, **741**, 129.
- 39 O. D. Fox, N. K. Dalley and R. G. Harrison, *Inorg. Chem.*, 2000, **39**, 620.
- 40 a) P. Delangle, J.-C. Mulatier, B. Tinant, J.-P. Declercq and J.-P. Dutasta, *Eur. J. Org. Chem.*, 2001, 3695; b) B. Bibal, J.-P. Declercq, J.-P. Dutasta, B. Tinant and A.-G. Valade, *Tetrahedron*, 2003, **59**, 5849; c) B. Bibal, B. Tinant, J.-P. Declercq and J.-P. Dutasta, *Chem. Commun.*, 2002, 432; d) M. Melegari, C. Massera, F. Ugozzoli and E. Dalcanale *CrystEngComm*, 2010, **12**, 2057.
- 41 S. J. Park, J. W. Lee, S. Sakamoto, K. Yamaguchi and J.-I. Hong, *Chem.-Eur. J.*, 2003, **9**, 1768; b) S. J. Park, D. M. Shin, S. Sakamoto, K. Yamaguchi, Y. K. Chung, M. S. Lah and J.-I. Hong, *Chem.-Eur. J.*, 2005, **11**, 235.
- 42 E. Menozzi, M. Busi, R. Ramingo, M. Campagnolo, S. Geremia and E. Dalcanale, *Chem.-Eur. J.*, 2005, **11**, 3136.
- 43 M. Tadokoro, S. Mizugaki, M. Kozaki and K. Okada, *Chem. Commun.*, 2005, 1140.
- 44 H. E. Moll, D. Sémeril, D. Matt, L. Charbonnière and L. Toupet, *Dalton Trans.*, 2011, **40**, 4391.
- 45 W. Jiang, H. Zhang, J. Yang, Y.-Y. Liu, H.-Y. Liu, J.-F. Ma, *CrystEngComm*, 2014, **16**, 9638.
- 46 a) N. Sahin, D. Sémeril, E. Brenner, D. Matt, I. Özdemir and L. Toupet, *ChemCatChem.*, 2013, **5**, 1116; b) M. Kaloğlu, D. Sémeril, E. Brenner, D. Matt, İ. Özdemir and L. Toupet, *Eur. J. Inorg. Chem.* 2016, 1115.4.
- 47 H. E. Moll, D. Sémeril, D. Matt and L. Toupet, *Adv. Synth. Catal.*, 2010, **352**, 901.
- 48 H. E. Moll, D. Sémeril, D. Matt and L. Toupet, *Eur. J. Org. Chem.*, 2010, 1158.
- 49 T. Chavagnan, D. Sémeril, D. Matt, J. Harrowfield and L. Toupet, *Chem.-Eur. J.*, 2015, **21**, 6678.
- 50 T. Chavagnan, D. Sémeril, D. Matt, L. Toupet, J. Harrowfield and R. Welter, *Eur. J. Inorg. Chem.*, 2016, 497.
- 51 E. Solari, W. Lesueur, A. Klose, K. Schenk, C. Floriani, A. Chiesi-Villa and C. Rizzoli, *Chem. Commun.*, **1996**, 807.
- 52 T. E. Berridge, H. Chen, T. A. Hamor and C. J. Jones, *Polyhedron*, 1997, **16**, 2329.
- 53 K. Kobayashi and M. Yamanaka, *Chem. Soc. Rev.*, 2015, **44**, 449 and references therein.
- 54 a) P. Jacopozzi and E. Dalcanale, *Angew. Chem., Int. Ed. Engl.*, 1997, **36**, 613; b) F. Fochi, P. Jacopozzi, E. Wegelius, K. Rissanen, P. Cozzini, E. Marastoni, E. Fiscaro, P. Manini, R. Fokkens and E. Dalcanale, *J. Am. Chem. Soc.*, 2001, **123**, 7539.
- 55 L. Pirondini, F. Bertolini, B. Cantadori, F. Ugozzoli, C. Massera, and E. Dalcanale, *PNAS*, 2002, **99**, 4911.
- 56 L. Pirondini, D. Bonifazi, B. Cantadori, P. Braiuca, M. Campagnolo, R. De Zorzi, S. Geremia, F. Diederich and E. Dalcanale, *Tetrahedron* 2006, **62**, 2008.
- 57 R. Pinalli, V. Cristini, V. Sottili, S. Geremia, M. Campagnolo, A. Caneschi, and E. Dalcanale, *J. Am. Chem. Soc.*, 2004, **126**, 6516.
- 58 T. Haino, M. Kobayashi, M. Chikaraishi and Y. Fukazawa, *Chem. Commun.*, 2005, 2321.
- 59 S. J. Park, D. M. Shin, S. Sakamoto, K. Yamaguchi, Y. K. Chung, M. S. Lah and J.-I. Hong, *Chem. Commun.*, 2003, 998;
- 60 a) O. D. Fox, N. K. Dalley and R. G. Harrison, *J. Am. Chem. Soc.*, 1998, **120**, 7111; b) O. D. Fox, J. F.-Y. Leung, J. M. Hunter, N. K. Dalley and R. G. Harrison, *Inorg. Chem.*, 2000, **39**, 783.
- 61 O. D. Fox, N. K. Dalley and R. G. Harrison, *Inorg. Chem.*, 1999, **38**, 5860.
- 62 R. G. Harrison, N. K. Dalley and A. Y. Nazarenko, *Chem. Commun.*, 2000, 1387.
- 63 R. G. Harrison, O. D. Fox, M. O. Meng, N. K. Dalley and L. J. Barbour, *Inorg. Chem.* 2002, **41**, 838.
- 64 E. Menozzi, M. Busi, C. Massera, F. Ugozzoli, D. Zuccaccia, A. Macchioni and Enrico Dalcanale, *J. Org. Chem.* 2006, **71**, 2617.
- 65 M. Busi, B. Cantadori, F. Boccini, R. De Zorzi, S. Geremia and E. Dalcanale, *Eur. J. Org. Chem.*, 2011, 2629.
- 66 O. D. Fox, M. G. B. Drew and P. D. Beer, *Angew. Chem., Int. Ed.*, 2000, **39**, 136.
- 67 a) O. D. Fox, M. G. B. Drew, E. J. S. Wilkinson and P. D. Beer, *Chem. Commun.*, 2000, 391.; b) O. D. Fox, J. Cookson, E. J. S. Wilkinson, M. G. B. Drew, E. J. MacLean, S. J. Teat and P. D. Beer, *J. Am. Chem. Soc.* 2006, **128**, 6990.
- 68 O. Ugono, J. P. Moran and K. T. Holman, *Chem. Commun.*, 2008, 1404.
- 69 M. Nikan, B. O. Patrick and J. C. Sherman, *ChemBioChem*, 2012, **13**, 1413.
- 70 G. R. Desiraju, *Angew. Chem., Int. Ed. Engl.*, 1995, **34**, 2311.
- 71 R. Weyler, J. de Mendoza and J. Rebek Jr., *Angew. Chem., Int. Ed. Engl.*, 1993, **32**, 1699.
- 72 T. Heinz, D. M. Rudkevich and J. Rebek Jr., *Nature*, 1998, **394**, 764.
- 73 S. Mecozzi and J. Rebek Jr., *Chem. Eur. J.*, 1998, **4**, 1016.
- 74 R. G. Chapman, G. Olovsson, J. Trotter and J. C. Sherman, *J. Am. Chem. Soc.*, 1998, **120**, 6252.
- 75 C. Tucci, D. M. Rudkevich and J. Rebek Jr., *J. Am. Chem. Soc.*, 1999, **121**, 4928.
- 76 C. von dem Bussche-Hünnefeld; R. C. Helgeso; D. Bühring.; C. B. Knobler and D. J. Cram, *Croat. Chem. Acta*, 1996, **69**, 447.
- 77 a) S. Ma, D. M. Rudkevich and J. Rebek Jr., *J. Am. Chem. Soc.*, 1998, **120**, 4977; b) A. Shivanyuk, K. Rissanen, S. K. Korner, D. M. Rudkevich and J. Rebek Jr., *Helv. Chim. Acta*, 2000, **83**, 1778; c) A. R. Renslo, F. C. Tucci, D. M.

- Rudkevich and J. Rebek Jr., *J. Am. Chem. Soc.*, 2000, **122**, 4573.
- 78 K. Kobayashi, T. Shirasaka, E. Horn and N. Furukawa, *Tetrahedron Lett.*, 1999, **40**, 8883.
- 79 K. Kobayashi, T. Shirasaka, K. Yamaguchi, S. Sakamoto, E. Horn and N. Furukawa, *Chem. Commun.*, 2000, 41.
- 80 Kishimoto, M. Nakamura and K. Kobayashi, *Chem. Eur. J.*, 2016, **22**, 2629.
- 81 a) K. Kobayashi, K. Ishii, S. Sakamoto, T. Shirasaka and K. Yamaguchi, *J. Am. Chem. Soc.*, 2003, **125**, 10615; b) K. Kobayashi, K. Ishii and M. Yamanaka, *Chem.–Eur. J.*, 2005, **11**, 4725.
- 82 H. Kitagawa, M. Kawahata, R. Kitagawa, Y. Yamada, M. Yamanaka, K. Yamaguchi and K. Kobayashi, *Tetrahedron*, 2009, **65**, 7234.
- 83 K. Ichihara, H. Kawai, Y. Togari, E. Kikuta, H. Kitagawa, S. Tsuzuki, K. Yoza, M. Yamanaka and K. Kobayashi, *Chem.–Eur. J.*, 2013, **19**, 3685.
- 84 H. Kitagawa, Y. Kobori, M. Yamanaka, K. Yoza and K. Kobayashi, *Proc. Nat. Acad. Sci.*, 2009, **106**, 10444.
- 85 a) C. Aakeröy, N. Schultheiss and J. Desper, *Org. Lett.*, 2006, **8**, 2607.; b) C. B. Aakeröy, N. Schultheiss and J. Desper, *CrystEngComm*, 2006, **8**, 502; c) C. Aakeröy, N. Schultheiss and J. Desper, *CrystEngComm*, 2007, **9**, 211. d) C. B. Aakeröy and P. D. Chopade, *Org. Lett.*, 2011, **13**, 1; e) C. B. Aakeröy, P. D. Chopade, C. F. Quinn and J. Desper, *CrystEngComm*, 2014, **16**, 3796.
- 86 C. B. Aakeröy, A. Rajbanshi and J. Desper, *Chem. Commun.*, 2011, **47**, 11411.
- 87 C. B. Aakeröy, A. Rajbanshi, P. Metrangolo, G. Resnati, M. F. Parisi, J. Desper and T. Pilati, *CrystEngComm*, 2012, **14**, 6366.
- 88 L. Turunen, N. K. Beyeh, F. Pan, A. Valkonen and K. Rissanen, *Chem. Commun.*, 2014, **50**, 15920.
89. O. Dumele, N. Trapp and F. Diederich, *Angew. Chem. Int. Ed.*, 2015, **54**, 12339.
- 90 C. Massera, M. Melegari, F. Ugozzoli, and E. Dalcanale, *Chem. Commun.*, 2010, **46**, 88.
- 91 R. M. Yebeutchou, F. Tancini, N. Demitri, S. Geremia, R. Mendichi and E. Dalcanale, *Angew. Chem. Int. Ed.*, 2008, **47**, 4504.
- 92 B. Dubessy, S. Harthong, C. Aronica, D. Bouchu, M. Busi, E. Dalcanale and J.-P. Dutasta, *J. Org. Chem.*, 2009, **74**, 3923.
- 93 M. Kobayashi, M. Takatsuka, R. Sekiya and T. Haino, *Org. Biomol. Chem.*, 2015, **13**, 1647.
- 94 F. Tancini, R. M. Yebeutchou, L. Pirondini, R. De Zorzi, S. Geremia, O. A. Scherman, and E. Dalcanale, *Chem. Eur. J.*, 2010, **16**, 14313.
- 95 a) C. M. Kane, O. Ugono, L. J. Barbour, and K. T. Holman, *Chem. Mater.* 2015, **27**, 7337; b) C. M. Kane, A. Banisafar, T. P. Dougherty, L. J. Barbour and K. T. Holman, *J. Am. Chem. Soc.*, 2016, **138**, 4377.



Roberta Pinalli received her scientific training at the University of Parma, graduating in Industrial Chemistry in 1998. After a two year stint in Antibioticos SpA, as process chemist, she obtained her PhD in Chemistry from the same University in 2002, under the supervision of Prof. Dalcanale, working on nanosize coordination cages. During her PhD

tenure she spent a semester at the University of Twente, in the group of Prof. D.N. Reinhoudt.. After a three year experience as senior researcher in Bracco Imaging SpA, she rejoined Dalcanale's group. Currently she is Assistant Professor at the University of Parma. Her research interests focus on supramolecular chemistry, sensors and advanced materials.



Enrico Dalcanale graduated in Industrial Chemistry (summa cum laude) at the University of Bologna in 1981. After working as research scientist at the Donegani Research Institute from 1982 to 1990, he joined the Faculty of the Department of Chemistry of the University of Parma, where he is

currently Professor of Industrial Chemistry. In 1985-86 he spent a sabbatical year in the group of D. J. Cram (Nobel Laureate 1987) at UCLA. His research interests include molecular recognition, supramolecular sensors, self-assembly of nanostructures on surfaces, supramolecular polymers. He is recipient of two national prizes for his work in the field of supramolecular chemistry. He is the founder of SOATEC, a spin-off company active in the field of environmental and food sensors. In 2004 he has been visiting professor at Naval Research Laboratory (Washington DC). He is presently the Scientific Director of the Functional Materials section of the INSTM and coordinator of the PhD school in Materials Science at the University of Parma.



Franco Ugozzoli started his scientific career at the University of Parma, graduating in Physics in 1982 with a thesis on diffraction of Mössbauer γ rays. After a period at the Institute of Structural Chemistry, he joined the Faculty of Engineering in 1990 being

promoted Associate Professor in 1998 and Full Professor of "Fundamentals of Chemistry for Technology" in 2000. His research focuses on supramolecular chemistry and crystal engineering using X-ray diffraction methods and theoretical calculations. He has published 215 papers in international journals and has been an active participant in several research projects supported by the European Community.



Prof. C. Massera received her PhD from the University of Parma in 2001, with a thesis on the synthesis and structural characterisation of transition metal selenido-carbonyl clusters. After a period of study in Strasbourg with Prof. Pierre Braunstein, and in Marburg in the group of Prof. G. Frenking, she started

working at the Chemistry Department of the University of Parma with Prof. F. Ugozzoli. Her main research interests focus on the structural analysis of supramolecular complexes and coordination compounds, molecular recognition phenomena and structure-function correlations through single crystal X-ray diffraction techniques.

